

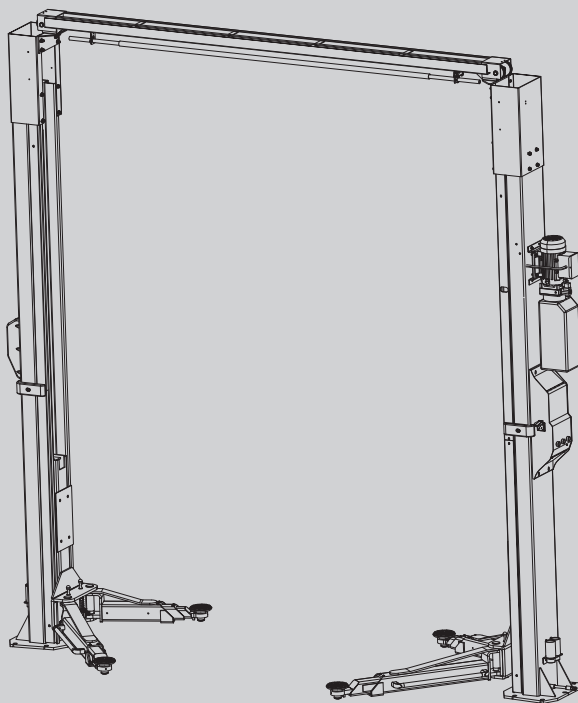

**4.5 吨新能源电动龙门举升机**  
**4.5T 2 Post Electric Lift Clear Floor Of New Energy Vehicles**

**AE5153EV/ AE5153EV-3**



使用说明书 \ User's Manual





## 目 录

第一章 安全注意事项 .....	4
第二章 产品特性和参数 .....	5
第三章 安装准备 .....	9
第四章 安装指导 .....	11
第五章 保养指导 .....	15
第六章 常见问题 .....	16
第七章 液压系统图及部件清单 .....	17
第八章 电气原理图 .....	18
第九章 产品爆炸图 .....	20
Chapter I Safety Precautions .....	26
Chapter II Product Features and Parameters .....	27
Chapter III Preparation for Installation .....	31
Chapter IV Installation Instructions .....	33
Chapter V Maintenance Instructions .....	38
Chapter VI Common Faults .....	39
Chapter VII Hydraulic System Diagram and Oil Pipe Routing Diagram .....	40
Chapter VIII Electrical Schematic Diagram .....	41
Chapter IX Exploded Views .....	42



## 第一章 安全注意事项

- 当您使用举升机时，必须保证您已经完全阅读了此说明书，包括安装，操作，安全等相关内容。
- 发现举升机有任何异常问题，停止使用。
- 不要超载使用举升机，本产品额定负载 4500KG。
- 当车辆准备开往上车位置前，先将四个托臂摆开，保证车辆通道没有任何障碍，不要用脚踹托臂，这样会损坏托臂齿。
- 只有接受过培训的人才可以操作举升机，禁止让汽车客户或者没有操作经验的人随意操作举升机。
- 举升机托臂的橡胶托盘必须与车辆的支撑点接触，否则会损坏车辆底盘。[不清楚支撑点位置的情况下，建议电话咨询车辆生产厂家]
- 举升车辆前，必须确保所有托臂齿成功啮合。
- 必须使用 4 个托臂同时举升汽车，禁止使用少于 4 个托臂举升汽车。
- 当举升完汽车后，必须执行机械落锁动作，禁止在没有机械落锁的情况下，在车辆下方工作。
- 当需要拆装汽车部件或者需要前后推动车辆时，车辆重心会偏离，为了保证安全，需要使用四个独立的支架来加强车辆稳定性。
- 举升机周边必须干净，整洁，任何油污等障碍物都是安全隐患。
- 禁止在车内有人员的情况下将车辆举起。
- 下降车辆前，确保下方没有任何障碍物。
- 车辆驶出举升机前，先将托臂摆回初始位置，确保不会与车辆干涉。
- 在液压系统有压力的情况下，禁止拆卸任何液压件。
- 不要将手放入任何危险的点，例如保险块，钢丝绳，滑台与立柱间隙，链条，电气连接点等。
- 本产品只适用在室内，禁止在室外使用。
- 短托臂安装在前方，长托臂安装在后方。[一般汽车前置发动机]
- 保险绳必须牢固，当拉动保险手柄时，主副立柱保险块必须同时完全同步打开。
- 操作人员必须穿戴安全鞋操作举升机。
- 整机质保一年。

## 第二章 产品特性和参数

### 2.1 产品特点

- 双油缸直驱，减少中间环节，更安全
- 立柱采用双 S 型截面设计，强度更高
- 3 节托臂设计，适用车型广泛
- 具备上限位功能，保护车顶免受损坏
- 非对称安装，方便车门在修理过程中开得更大
- 设有静电释放装置，保护人车安全
- 标配长方形导电托盘

### 2.2 产品技术参数：

额定举升重量	4500KG	
立柱内宽	3080mm（对称安装）/2971mm（不对称安装）	
整机高度	3900mm	
举升最低高度	110mm	
托盘调节高度	75mm	
举升最高高度	1820mm	
三节托臂伸缩范围	580mm~1140mm	
二节托臂伸缩范围	900mm~1430mm	
电机参数	AE5153EV-3	3PH,380VAC,2.2KW, 铝合金外壳电机
	AE5153EV	1PH,220VAC,2.2KW, 铝合金外壳电机
液压油类型	ISO 46# 抗磨液压油	

对称安装产品示意图 (单位: mm)

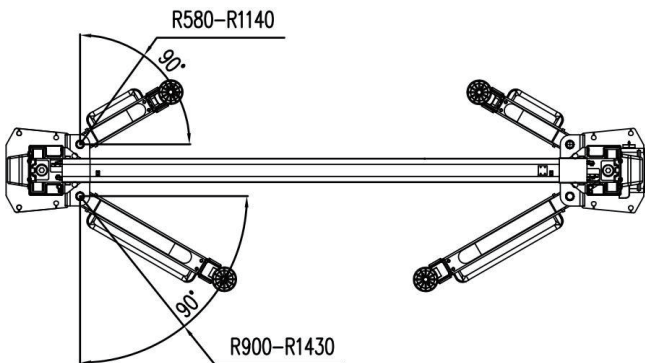
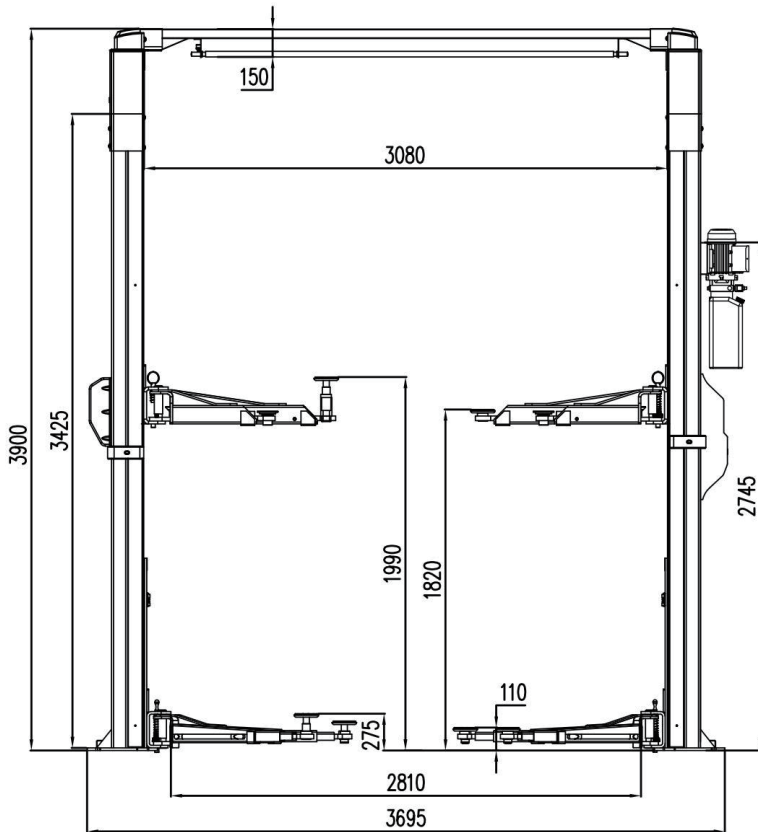

非对称安装产品示意图 (单位: mm)

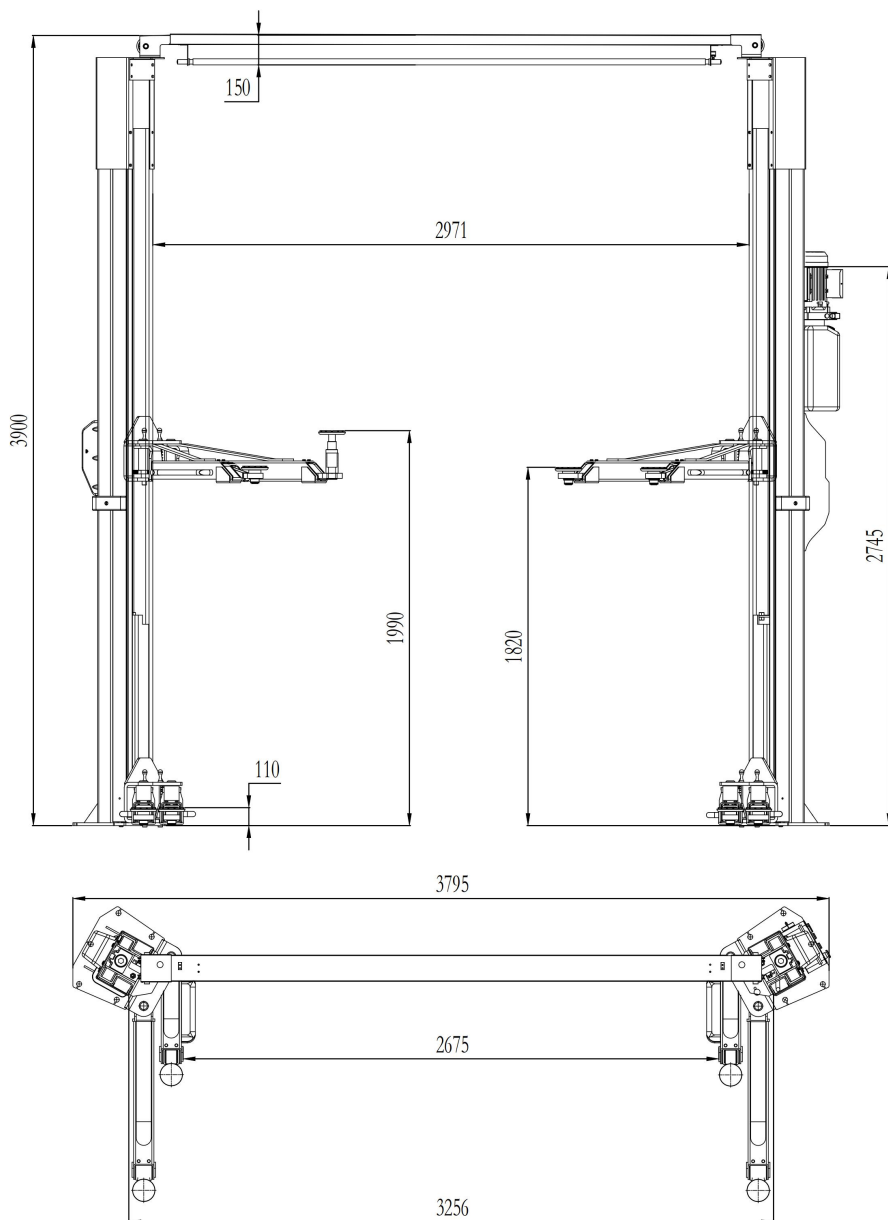

**主要部件简介：**

- 本机主要由主立柱，副立柱，滑台，托臂，锁臂装置，托臂锁，机械锁，油缸，动力单元，横梁等组成。  
 (看下图)

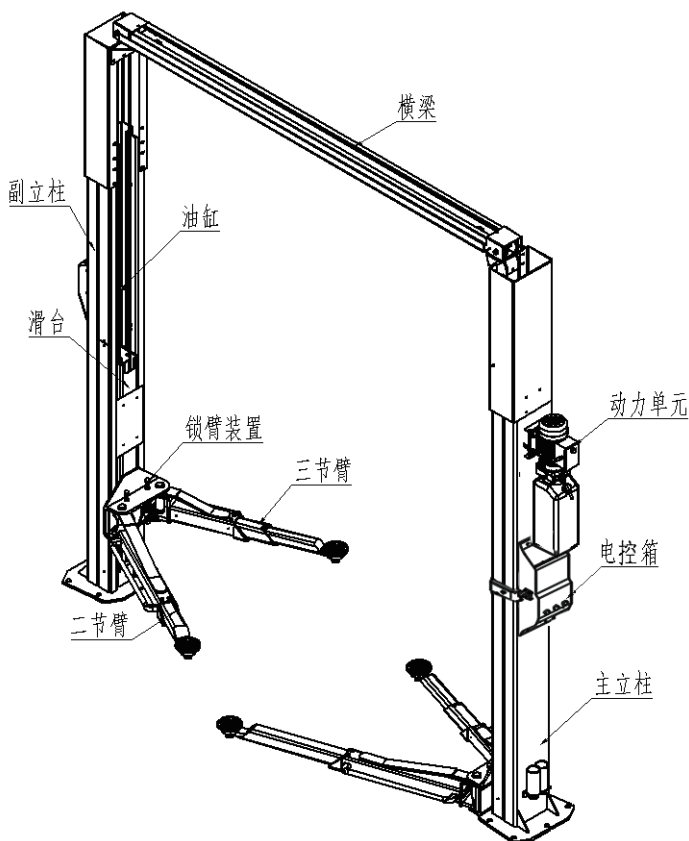

立柱：基础部件，用于安装滑台，油缸等驱动装置

滑台：举升部件，装在立柱内，上下滑动

托臂：举升部件，与滑台安装在一起，与汽车支撑点接触，举升汽车

锁臂装置：安全部件，锁止托臂，使其无法转动

油缸：传动部件，液站工作，将高压油打入油缸下腔，活塞杆上升，带动滑台上升

动力单元：动力部件，电机工作，带动泵工作，通过过滤网吸油，推出高压油

横梁：过桥部件，平衡钢丝绳，油管，保险绳通过龙门架从主立柱到副立柱，同时减轻了两立柱的内侧

电控箱：24V 控制电路，控制上升、下降和锁定



## 第三章 安装准备

### 拆卸包装

- 将包装箱拆开，去掉周围的包装材料，检查机器有无在运输中受损，对照装箱单检查主、配物件是否齐全。将包装材料远离儿童放置，以免造成危险；若包装材料会造成污染，应将其妥善处理。

### 地基

- 用户有责任确保地基的稳固，混凝土的最小厚度为 500mm，最小强度为 21MPa，混凝土必须在安装日 15 天之前完成。与膨胀螺栓相距 350mm 内不允许有其它任何地基设备以免破坏地基强度。用户有责任提供安全的电源，气源，以及电源连接线等连通部件。

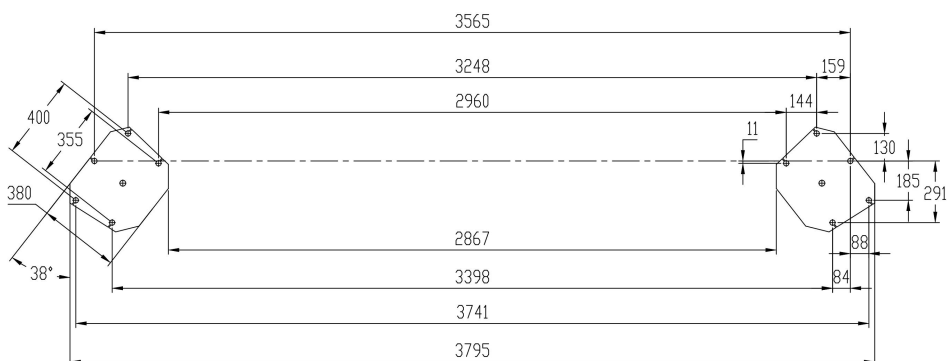
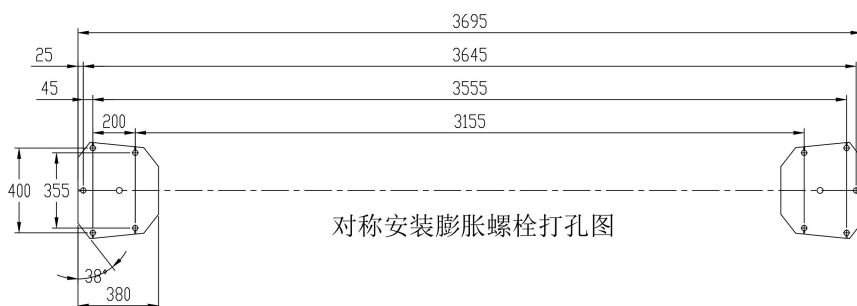

不对称安装膨胀螺栓打孔图

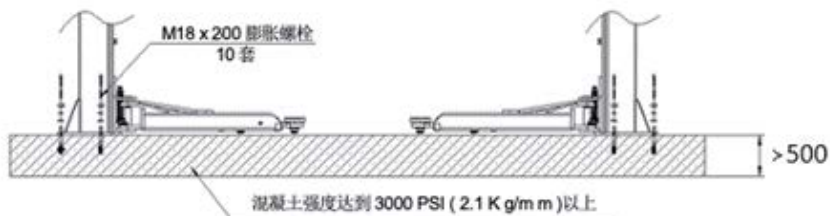

电机位置, 电源线到达位置  
 380V 三相五线  
 380V/ 3KW /50Hz

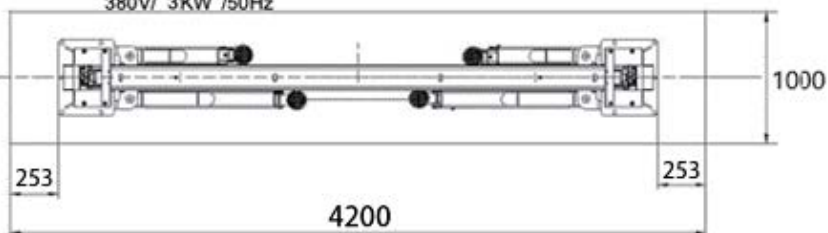

## 工具

- 5m 卷尺
- 石粉笔
- 合适的冲击钻和钻头 (膨胀螺栓 M18X200mm)
- 锤子
- 合适的扳手
- 1.2m 的水平尺
- 撬棍
- 4m 高扶梯
- 合适的螺丝刀
- 100mmx100mm 的木砌 (用于平放立柱, 保护油漆表面)

## 第四章 安装指导

- 首先选择好要安装的区域，尽量靠墙，离电源近的地方
- 清理干净安装举升机区域，地面不可以有任何油污
- 产品安装空间尺寸图供参考

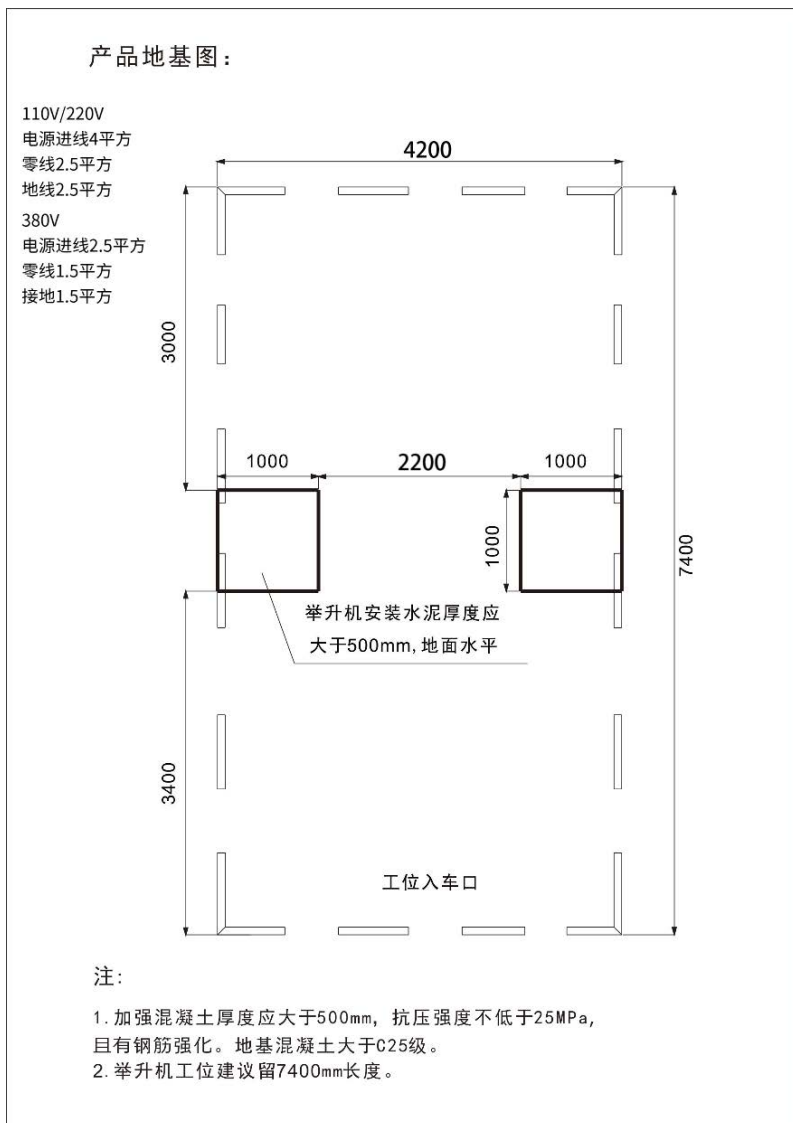

- 将主立柱放置好，用冲击钻打孔，将螺栓孔内残余的灰尘用吸尘器清理干净，用锤子将膨胀螺栓敲入孔内，膨胀螺栓露出地面高度不可大于 50mm，螺母不要拧紧。

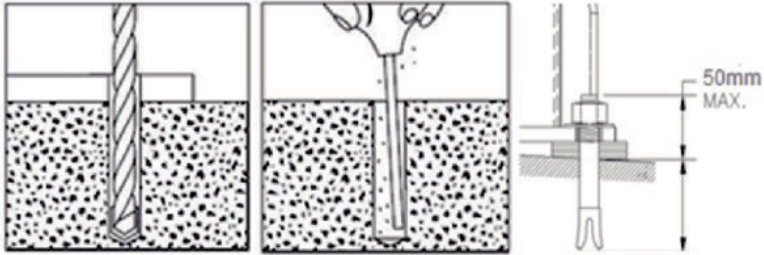

- 将副立柱固定，方法参照主立柱，同时确认两立柱底板对角线距离差在 3mm 以内。
- 两边立柱各准备好扶梯推车，用吊带拴好龙门架两边，将龙门架吊起，固定好连接螺栓。

**注意：安装龙门架时，升降机周围不可以有其他人员。**

- 拧紧膨胀螺栓（参考扭力 203N.m），同时用水平尺确认立柱的垂直，如有必要，用垫片塞入立柱底部，调整水平，龙门架上表面也用水平尺确保水平。

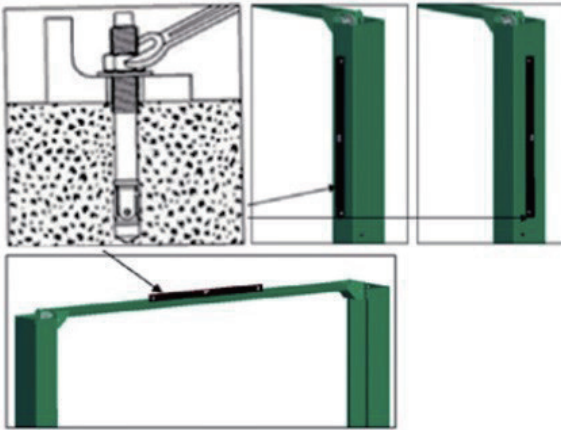

**注意：如果拧紧膨胀螺栓的时候无法达到 203N.m，应该重新确认混凝土的强度。**

- 安装车顶防撞限位杆，并连接好限位开。

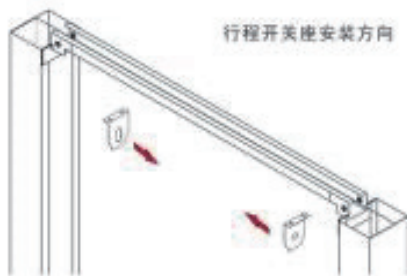

### - 安装平衡钢丝绳

保证左右两边滑台在第一档保险处，将平衡钢丝绳按图示轨迹安装好。先不要拧紧螺母，等调试同步性的时候，再调整两根钢丝绳的松紧。注意：单边钢丝绳螺杆必须拧紧，调节时必须确保两边滑台锁在同一高度的锁上。

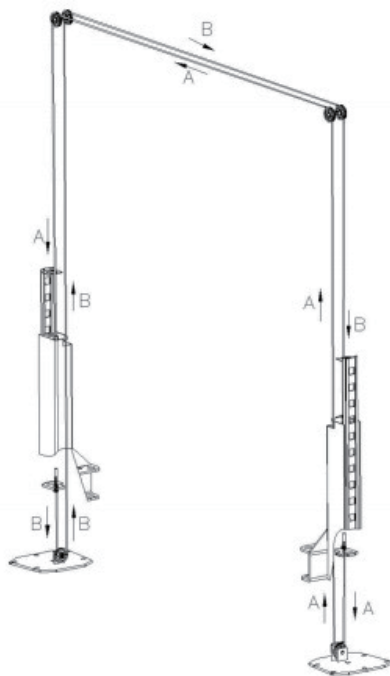

### - 托臂安装

通过销轴将四个托臂装入滑台，前端用三节臂，后端用二节臂。〔注意：车头方向使用三节托臂，每个托臂轴需要装好卡簧〕

当小齿跟大齿距离调整好后，把大齿固定螺丝拧紧  
After making sure the lock match perfectly, tightening the screws.

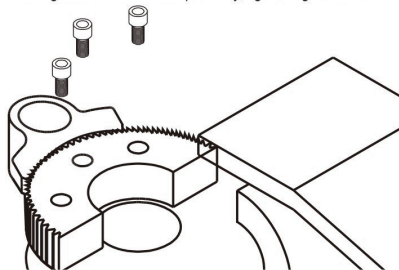

### - 动力单元装配

将动力单元安装于主立柱电机板上，用螺栓螺母固定。安装好限位开关，连接电线。

- 液压系统连接

- 拧开油箱盖，倒入 10L--46# 抗磨液压油。〔首选 46# 抗磨液压油，温度 -10° C 以下，考虑 32#〕
- 连接好液压接头，将油管连接于主副油缸出口口接头处。

- 安装电解锁电路的方式

电解锁电线安装方式如下图所示安装，分别接入电线的 2、7 号和 9、10 号端子。

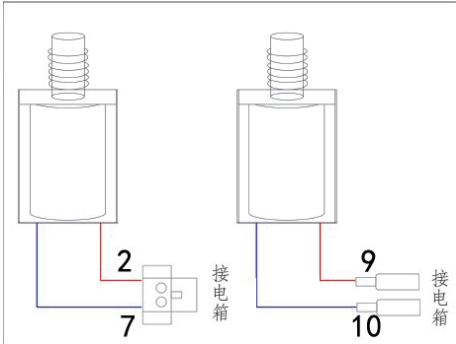

- 电解锁保险安装方式：

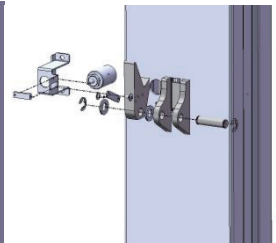
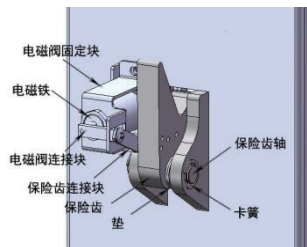
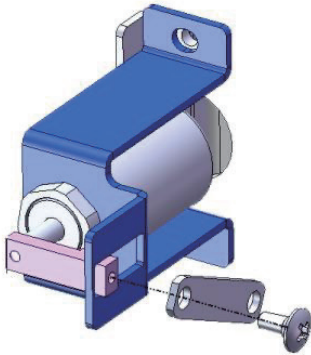

- 注意：

保险与轴之间应加注通用锂基润滑脂（GB7324-87），正常使用时保证保险安全靠如保险不能复位，应立即停机，不得举升作业，待问题排除后方可使用

- 空载测试调整

- 清理场地，地面不可以有油污，举升机空载。
- 接通电源，按上升按钮，滑台上升，任意位置停止上升，按回油手柄，将左右滑台落入同档保险
- 拧紧平衡钢丝绳螺母，使两根平衡钢丝绳松紧度基本一致。
- 按上升按钮，使滑台上升一段距离，脱离保险，左手拉保险手柄，右手按回油手柄使滑台下降到最低处。
- 按上升按钮，全程举升，任意位置触动限位开关，电机停止运转，达到极限位置时溢流阀打开，液压系统回油，滑台停止上升，举升过程观察左右滑台托臂同步性，如果有明显差异，继续调整平衡钢丝绳螺母松紧达到左右滑台同步性。
- 安装车门防撞橡胶垫。

#### - 负载测试调整

- a. 将四个托臂完全打开，确保车道空间无任何障碍。
- b. 将汽车驶入举升机，左右居中，以立柱连线做参考，车辆前后放置距离比大致 2:3(前置发动机车辆)，当车辆吨位大于 3.5 吨时，适当向后移动车辆。
- c. 将托臂托盘旋转至汽车底盘支撑点。
- d. 按上升按钮，托臂上升，确认四个托臂锁完全落锁。
- e. 继续点动上升，观察如果有任一橡胶托盘接触到底盘支撑点，停止上升，然后将余下的橡胶托盘逆时针旋转，与支撑点接触。
- f. 按上升按钮，汽车慢慢被提起，当汽车轮胎离地时，停止上升。轻推汽车尾部，确认汽车安全稳固，托臂锁完全落锁。
- g. 按上升按钮，汽车继续上升，观察汽车举升过程前后左右是否平稳，当滑台上升到第三或者第四档保险的时候，停止上升，按锁定按钮，液压站回油，滑台落锁。观察汽车前后左右是否平稳。(如果左右高低差明显，则调节平衡钢丝绳螺母)。
- h. 继续上升至最高一档保险，停止上升，按锁定按钮，回油落锁。观察举升机是否平稳无颤动。
- i. 点动上升，滑台脱离保险，按下降按钮，汽车下降。
- j. 中间任意位置，松开下降按钮，保险自动回弹，滑台落锁，停止下降。
- k. 点动上升，滑台脱离保险，按锁定按钮，保险自动回弹，滑台落锁，停止下降。这样的动作循环三次以上，确认机械保险安全而可靠。
- l. 举升汽车过程中，观察是否有异响，钢丝绳与其它部件是否有摩擦干涉。

## 第五章 保养指导

#### - 每日检查项目

- 检查所有液压接头，油管，油缸是否存在漏油。
- 检查所有电气接线线是否有破损。
- 检查所有运动部件是否有过劳磨损。
- 清理橡胶托盘上的油污，观察橡胶托盘是否有过渡磨损。

#### - 每 2 个月检查项目

- 更换立柱滑道内的润滑脂
- 更换托臂销轴的润滑脂
- 检查并锁紧膨胀螺栓螺母

#### - 每 6 个月检查项目

- 更换链条钢丝绳润滑脂
- 调节平衡钢丝绳，保险绳
- 检查钢丝绳是否有毛刺

#### - 每 2 年检查项目

- 更换液压油



## 第六章 常见问题

序号	常见问题	解决方案
1	按钮无法工作	更换按钮
2	接触器通电不吸合	更换接触器
3	接触器无法得电吸合	检查按钮与限位开关
4	液压系统连接处漏油	更换接头或者油管
5	油缸漏油	更换密封圈，严重者直接更换油缸
6	托臂齿啮合不好	调节托臂齿位置
7	保险绳松动	调整锁紧保险绳锁扣
8	平衡钢丝绳严重毛刺	更换钢丝绳
9	左右滑台无法落入同档保险	调整平衡钢丝绳螺母，使滑台同步
10	自动回油下降	更换回油阀或者下降调速阀
11	三相电机旋转不出油	电机反转，更换相邻两根电源相线（俗称火线）
12	三相电机异响无力	电机缺相，万用表检查电源进线 380VAC
13	负载情况下将速度过慢	检查回油阀，下降速度阀是否有异物堵住
14	工作时颤抖	立柱滑道涂刷润滑脂，检查液压站输出压力是否足够稳定，检查油缸活塞杆是否有爬升现象。[ 更换 ]



## 第七章 液压系统图、油管接法图

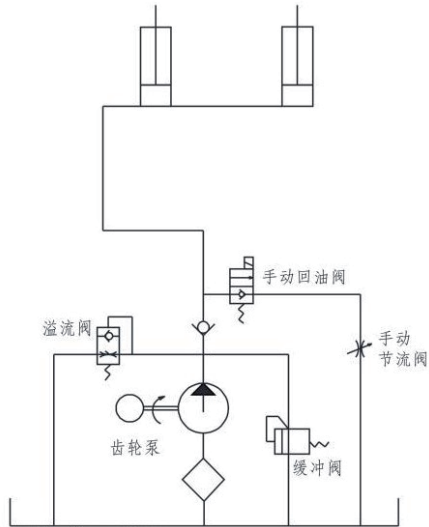

手动回油阀：控制下降油路  
 手动节流阀：调整下降速度  
 溢流阀：控制最大压力  
 齿轮泵：输出油压  
 缓冲阀：电机启动时减缓电机负载

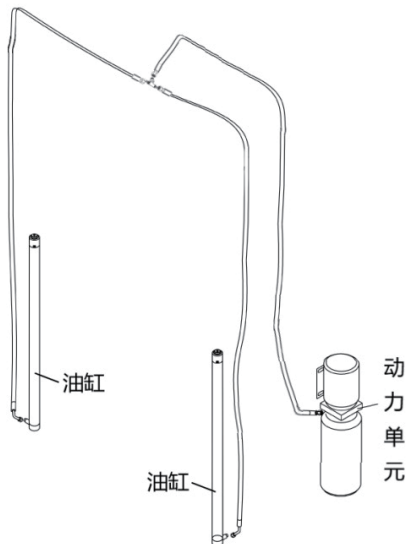

## 第八章 电气原理图

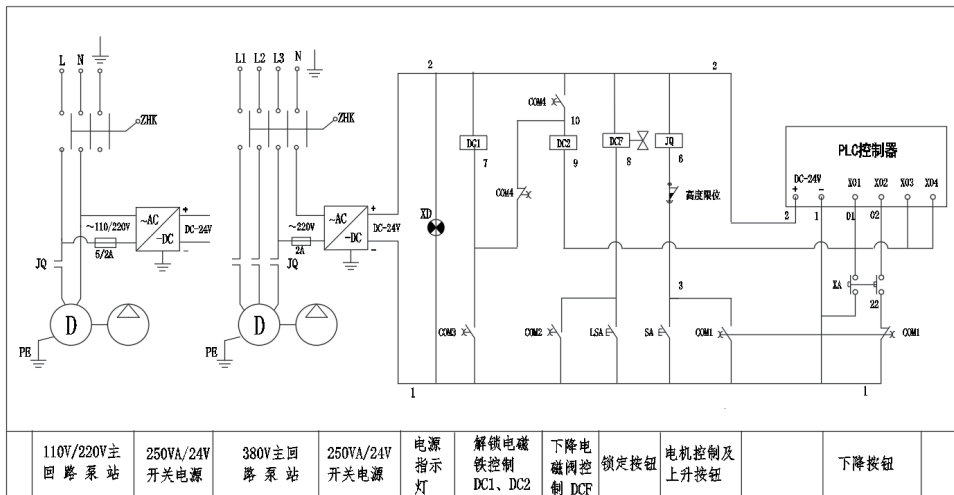



电压	功率	启动电流	工作电流	电线尺寸	空气开关	适用于
380V	3KW	21A-35A	8.5A	2.5 平方以上	C63	剪式举升机
220V	3KW	60A	21A-25A	4 平方以上	C63	剪式举升机
380V	2.2KW	18A-30A	7.5A	2.5 平方以上	C63	二柱、龙门、四柱
220V	2.2KW	60A	20A-22A	4 平方以上	C63	二柱、龙门、四柱

注意：电源入口UVW，请用2.5平方以上的电源线

电机接口XYZ，

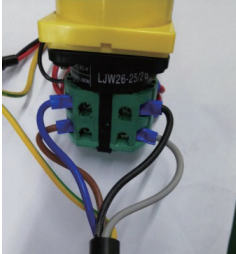
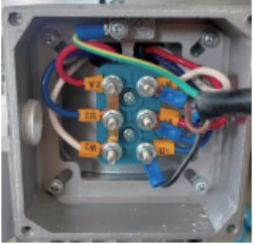
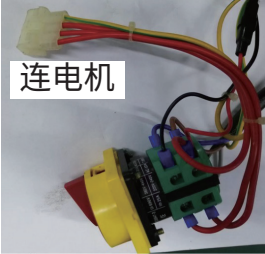
行程开关JE请接入C63空气漏电开关。

	
<p>电源接入线安装方式</p>	<p>电机线安装方式</p>
	
<p>电机线接线方式 (此线已留于线控盒外):              红为 3 条火线,              黄色为地线</p>	<p>3、6 接限位的行程开关, 2、8 接电机的下降阀, 2、7 和 9、10 接立柱上的电磁铁</p>

第九章 爆炸图

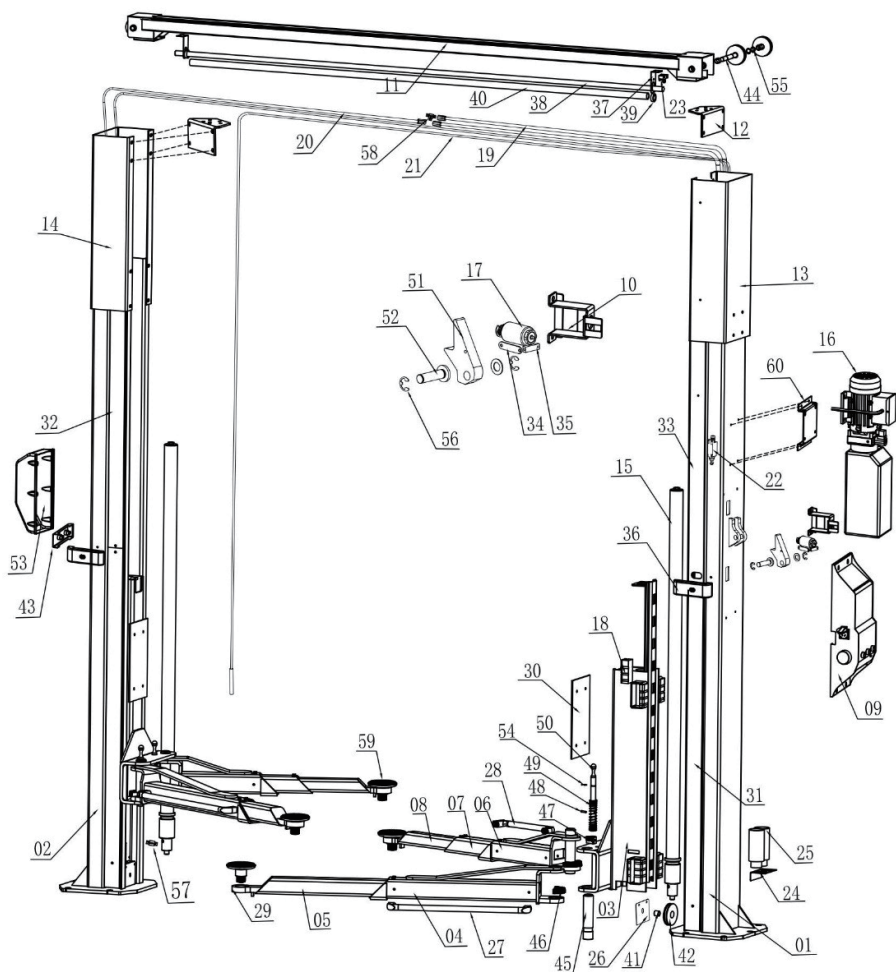

序号	世达编号	名称	序号	世达编号	名称
1	PAE5153-01	主立柱	30	PDAE5141-14	车辆保护橡胶垫
2	PAE5104-02	副立柱	31	PAE5153-07	油管盖板底
3	PAE5104-03	滑台	32	PAE5153-08	油管盖板顶 (副)
4	PAE5104-04	长摇臂 A	33	PAE5153-09	油管盖板顶 (主)
5	PAE5104-05	长摇臂 B	34	PAE5153-10	保险齿连接块
6	PAE5104-06	短摇臂 A	35	PAE5153-11	电磁阀连接块
7	PAE5104-07	短摇臂 B	36	PAE5153-12	大架线槽块 A
8	PAE5104-08	短摇臂 C	37	PDAE5140-12	顶部限位开关固定块
9	PAE5153-02	电控箱 220V	38	PDAE5140-13	限位管
	PAE5153-03	电控箱 380V	39	PDAE5140-14	限位杆固定套
10	PAE5153-04	电磁阀固定块	40	PDAE5140-15	泡棉套管
11	PAE5104-09	横梁	41	PDAE5040-37	M20X20 耐磨圈
12	PAE5104-10	立柱连接块	42	PAE5104-16	钢丝绳滚轮
13	PAE5104-11	立柱主加高套	43	PAE5153-10	大架线槽块 B
14	PAE5104-12	立柱副加高套	44	PDAE5140-16	横梁滑轮轴
15	PDAE5141-07	油缸	45	PDAE5040-42	摇臂下保险齿固定轴
16	PDAE5141-08	380V 动力单元	46	PDAE5040-44	大齿轮
	PDAE5141-09	220V 动力单元	47	PDAE5040-45	小齿轮
17	PAE5153-05	电磁铁	48	PDAE5141-20	5mm 开口销
18	PDAE5141-10	滑块 A	49	PDAE5040-46	摇臂上保险齿拉簧
19	PAE5153-06	短油管 L3080	50	PDAE5040-47	摇臂上保险齿拉杆轴
20	PDAE5141-12	长油管 L5480	51	PAE5153-13	保险齿
21	PDAE5141-13	钢丝绳组件 L10150	52	PAE5153-14	电动保险齿轴
22	PDAE5040-24	限位开关	53	PDAE5040-30	保险齿外罩 A
23	PDAE5140-07	微动开关	54	PDAE5040-51	M22 卡簧
24	PAE5104-13	增高柱底座	55	PDAE5141-21	M20 卡簧
25	PDAE5040-27	增高柱	56	PDAE5040-53	M17 卡簧
26	PDAE5140-08	大架底板钢丝轮罩	57	PDAE5040-54	双柱油缸长接头
27	PAE5104-14	长摇臂拉手	58	PAE5510-85	三通接头
28	PAE5104-15	短摇臂拉手	59	PAE5104-19	长方形托盘总成
29	PDAE5040-33	摇臂调节螺丝	60	PAE5153-15	动力单元安装架

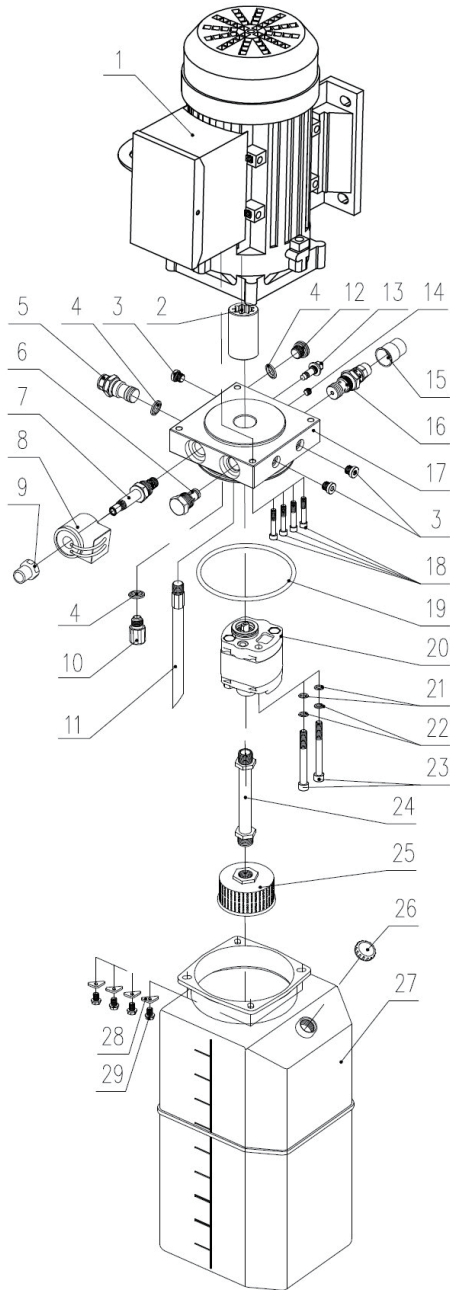

序号	世达编号	名称
1	PDAE5141-24	铝壳电机 220V
	PDAE5141-25	铝壳电机 380V
2	PDAE5040-58	花键连接套
3	PDAE5040-59	内六角堵头
4	PDAE5040-60	组合垫圈
5	PDAE5040-61	活接式油管接头
6	PDAE5040-62	单向阀
7	PDAE5153-30	下降阀芯
8	PDAE5153-31	下降阀芯磁铁
9	PDAE5153-32	锁紧螺帽
10	PDAE5040-66	缓冲阀
11	PDAE5040-67	回油管
12	PDAE5040-68	内六角堵头
13	PDAE5040-69	节流调节螺钉
14	PDAE5040-70	Φ8 球堵
15	PDAE5040-71	溢流阀胶盖
16	PDAE5040-72	溢流阀
17	PDAE5040-73	铝阀块
18	PDAE5040-74	内六角螺栓
19	PDAE5040-75	O 形圈
20	PDAE5040-76	齿轮泵
21	PDAE5040-77	平垫片
22	PDAE5040-78	弹簧垫
23	PDAE5040-79	内六角螺栓
24	PDAE5040-80	尼龙吸油管
25	PDAE5040-81	过滤器
26	PDAE5040-82	通气帽
27	PDAE5040-83	挂式方形塑料油桶
28	PDAE5040-84	油箱三角垫片
29	PDAE5040-85	外六角法兰螺栓

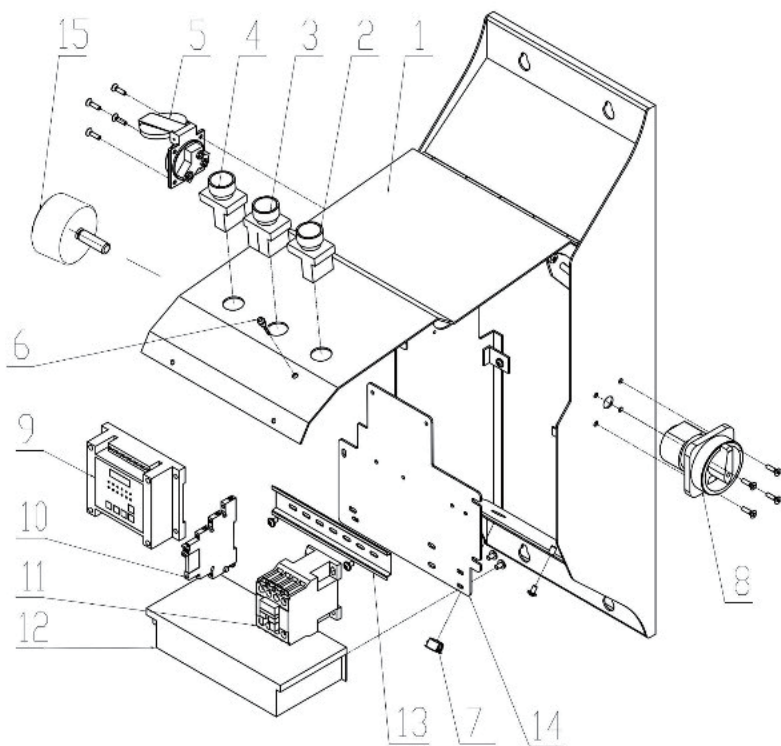



序号	世达编号	名称
1	PAE5153-16	电控箱 240X678X146
2	PAE5153-17	按钮〔锁定〕
3	PAE5153-18	按钮〔下降〕
4	PAE5153-19	按钮〔上升〕
5	PAE5153-20	工业带盖插座
6	PAE5153-21	指示灯〔红〕/LED6-24DC
7	PAE5153-22	堵头 /DT-16
8	PAE5153-23	万能转换开关 /LJW26-25-2GS-D
9	PAE5153-24	4路可编程时间继电器 /PLC-4MR
10	PAE5153-25	片式继电器 /HF41F-24-ZS
11	PAE5153-26	交流接触器 /CJX2-1810B
12	PAE5153-27	开关电源 /S-250-24
13	PAE5153-28	导轨 /C45-160
14	PAE5153-29	电控板
15	PAE5104-20	静电释放器



## Chapter I      Safety Precautions

- Make sure that you have read the User's Manual completely including relevant instructions on installation, operation and safety before operating the lift.
- Do not use the lift if any abnormality is found in the lift.
- Do not overload the lift (rated capacity: 4,500kg).
- Put the four bracket arms aside to ensure that the track is barrier-free before driving to the entry position. Do not kick the bracket arm as this may damage the bracket arm teeth.
- The lift can be operated by trained personnel only. The vehicle customer or the inexperienced person is prohibited from operating the lift at will.
- The rubber tray of the lift bracket arm must have contact with the support point of the vehicle; otherwise, the vehicle chassis may be damaged. (It is recommended to consult the vehicle manufacturer by telephone if the location of the support point is not clear.)
- Ensure that all bracket arm teeth are engaged successfully before lifting the vehicle.
- Always lift the vehicle with all the four bracket arms at the same time. Never lift the vehicle with less than 4 bracket arms.
- Be sure to perform mechanical locking after the vehicle is lifted. It is forbidden to work under the vehicle before mechanical locking is performed.
- The centre-of-gravity position of the vehicle may change when you install or remove any automobile component or push the vehicle forward and backward. To ensure safety, four independent brackets should be applied to improve the stability of the vehicle.
- Keep the area around the lift clean and tidy as any oil stain or obstacle may pose a safety risk.
- Never lift the vehicle with people in it.
- Make sure there is no obstacle under the vehicle before lowering it.
- Move the bracket arms back to original positions and ensure that they will not interfere with the vehicle before driving away from the lift.
- Do not remove any hydraulic component when the hydraulic system is under pressure.
- Do not put your hands at such dangerous positions as safety block, wire rope, gap between sliding table and post, chain, electrical connection, etc.
- Do not use the product outdoors as it is only suitable for indoor use.
- The short bracket arm is installed in the front while the long bracket arm is installed in the rear. (as most vehicles are equipped with front engine)
- The safety rope must be firm. When the safety handle is pulled, the safety blocks of the main and auxiliary posts must be opened completely and synchronously.
- Always wear safety shoes during operation.
- The whole machine is guaranteed for one year.

## Chapter II Product Features and Parameters

### 2.1 Product Features:

- Dual cylinder direct drive, reducing intermediate links and making it safer
- The columns are designed with dual S-sections for higher strength
- 3-section arm design for a wide range of models
- The limit switch on the beam protects the top of the car from damage
- Asymmetrical installation allows the doors to be opened wider during the repair process
- Equipped with static discharge device to protect the safety of people and vehicles
- Rectangular conductive tray as standard

### 2.2 Technical parameters:

Rated lifting capacity	4500KG	
Inner width of the post	3080mm (Symmetrical installation) /2971mm (Asymmetrical installation)	
Height of the lift	3900mm	
Minimum lifting height	110mm	
Tray adjustment height	75mm	
Maximum lifting height	1820mm	
Telescopic range of 3-section bracket arm	580mm-1140mm	
Telescopic range of 2-section bracket arm	900mm-1430mm	
Motor parameters	AE5153EV-3	3PH, 380VAC, 2.2KW, motor with an aluminum alloy housing
	AE5153EV	1PH, 220VAC, 2.2KW, motor with an aluminum alloy housing
Type of hydraulic oil	ISO 46# anti-wear hydraulic oil	

Diagram of symmetrically mounted product (unit: mm)

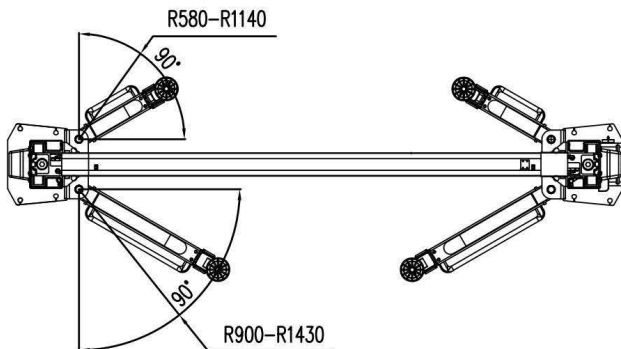
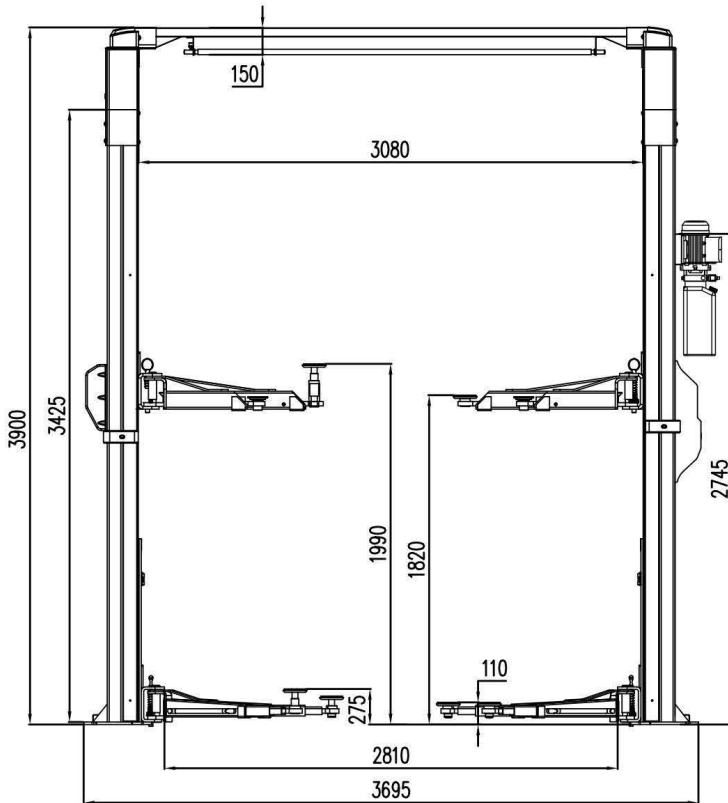
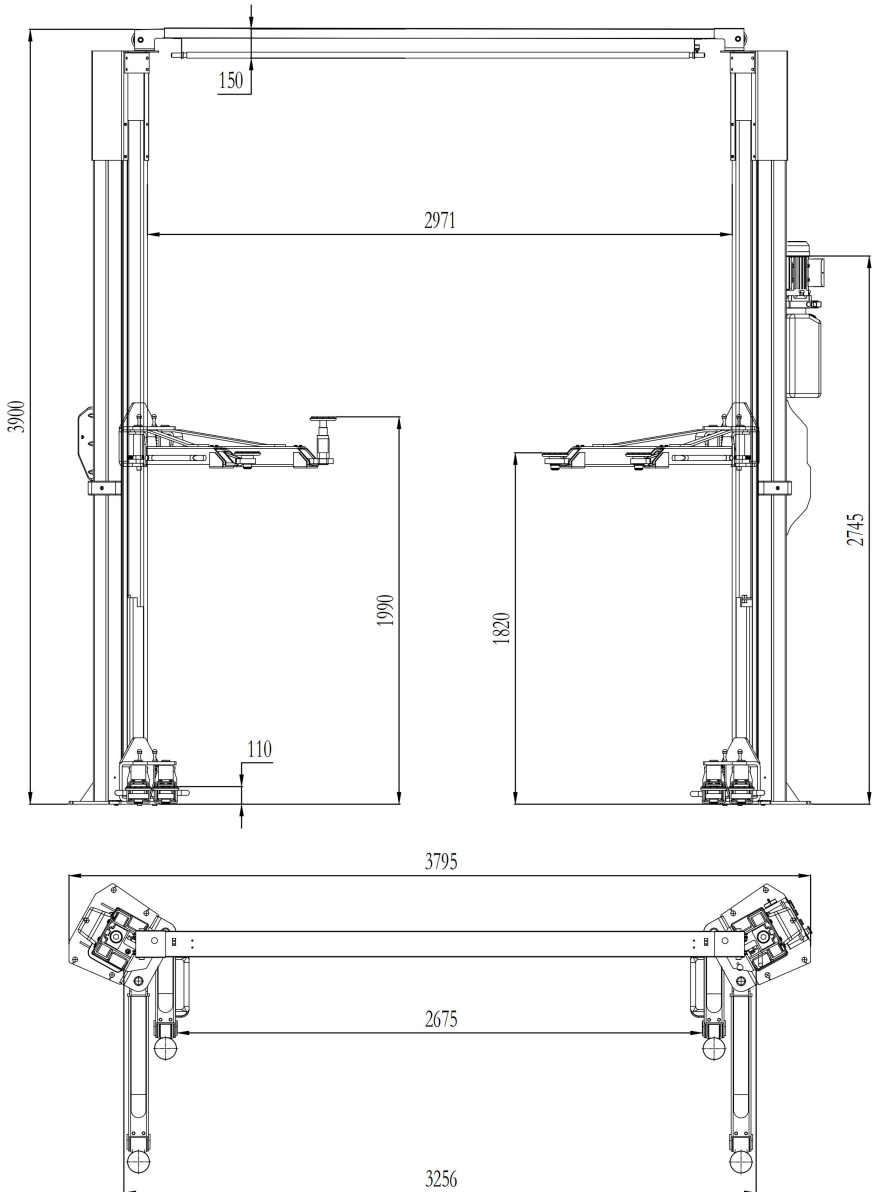
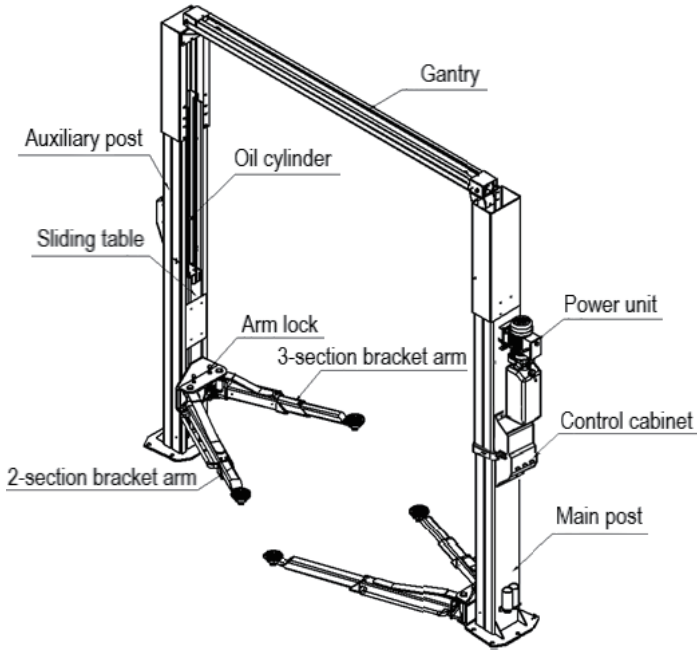

Diagram of asymmetrically mounted product (unit: mm)



### 2.3 Description of main components

- This machine mainly consists of the main post, auxiliary post, sliding table, bracket arm, arm lock, bracket arm lock, mechanical lock, cylinder, power unit, gantry, etc. (See the figure below)



Post: Basic component, carrying sliding table, cylinder and other drive devices;

Sliding table: Lifting component, installed inside the post, sliding up and down;

Bracket arm: Lifting component, installed together with the sliding table, having contact with the support point of the vehicle to lift the vehicle;

Arm lock: Safety component, locking the bracket arm to prevent it from rotation

Mechanical lock: Safety component. When the hydraulic oil is drained, the safety block pushes the safety strip to keep the sliding table still;

Cylinder: Drive component. When the hydraulic station pumps the high pressure oil into the lower chamber of the cylinder, the piston rod rises and drives the sliding table to rise;

Power unit: Power component. The motor drives the pump to suck oil via the filter strainer and pump high pressure oil

Gantry: Bridging component. The balance wire rope, oil pipe, and safety rope are arranged from the main post to the auxiliary post by way of the gantry, which also reduces the inward inclination of the two posts.

Control cabinet: 24V control circuit

## Chapter III Preparation for Installation

### Unpacking

- Open the packing case, remove the surrounding packing materials, inspect the machine for damage during transportation, and inspect the main components and accessories for completeness as per the packing list. Keep packing materials away from children so as not to pose any danger, and properly dispose them if they may cause pollution.

### Foundation

- The user has a responsibility to ensure the stability of the foundation. The concrete shall have a minimum thickness of 500mm and a minimum strength of 21MPa, and shall be properly prepared 15 days prior to the installation date. No other foundation equipment is allowed within 350mm of the expansion bolt to avoid degrading the foundation strength. The user has a responsibility to provide safe power, air source, and such connecting components as power wire.

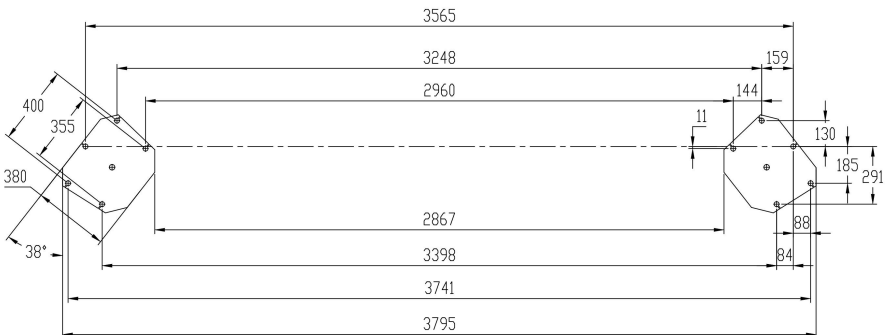
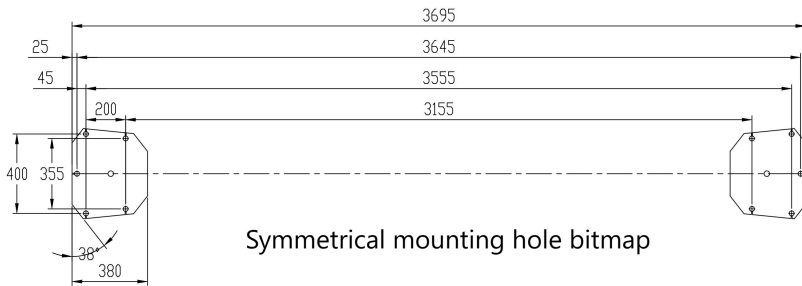

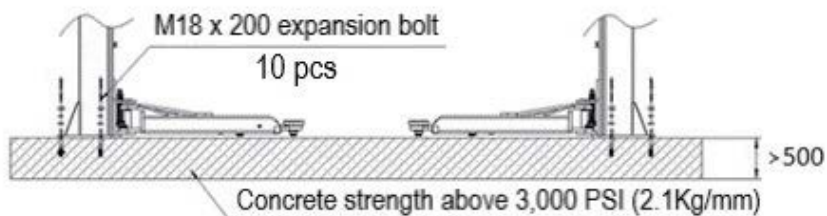

Motor position, the place to which the power wire extends  
380V three-phase five-wire 380V/ 3Kw /50Hz

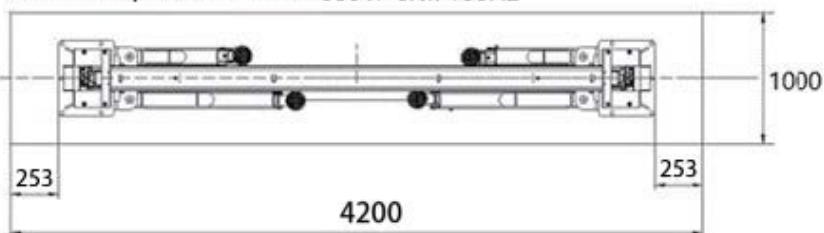

#### Tools

- a. 5m tape
- b. Chalk
- c. Proper impact drill and bit (expansion bolt M18X200mm)
- d. Hammer
- e. Proper wrench
- f. 1.2m spirit level
- g. Crowbar
- h. 4m ladder
- i. Proper screwdriver
- j. 100mmx100mm woodwork (for laying the post flat to protect the paint surface)



## Chapter IV Installation Instructions

- Determine the mounting position, which shall be close to wall and power as much as possible.
- Thoroughly clean the mounting position of the lift, which shall be free from oil stains.
- The dimension diagram of mounting space of the product is given below for reference only.

### Foundation diagram of the product

220V

Incoming power wire 4mm<sup>2</sup>

Neutral wire 2.5mm<sup>2</sup>

Ground wire 2.5mm<sup>2</sup>

380V

Incoming power wire 2.5mm<sup>2</sup>

Neutral wire 1.5mm<sup>2</sup>

Ground wire 1.5mm<sup>2</sup>

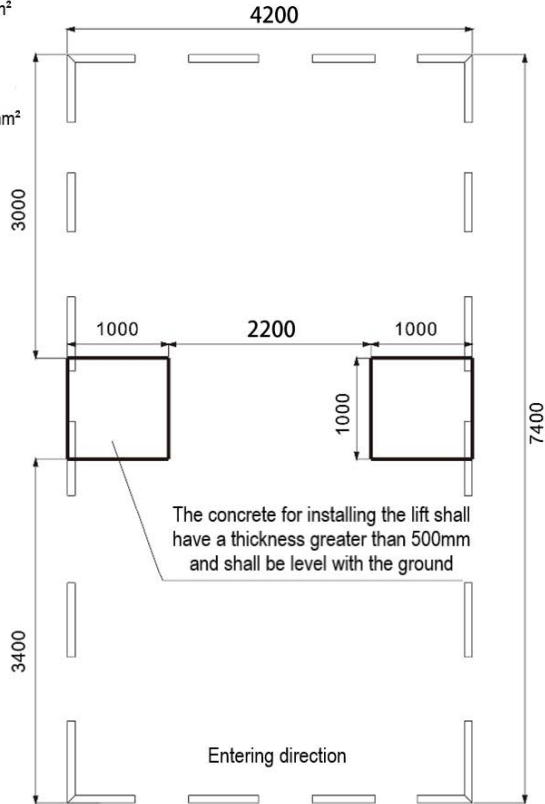

**Note:**

1. The concrete shall be reinforced with steel, and have a thickness greater than 500mm and a compressive strength not lower than 25MPa. The grade of the foundation concrete shall be greater than C25.
2. The lift station is recommended to have a length of 7,400mm.

- Properly position the main post, drill holes with the impact drill, remove the dust in the bolt hole with a vacuum cleaner, and hammer the expansion bolt into the hole. The length of the expansion bolt protruding from the ground shall not exceed 50mm, and the nut shall not be tightened.

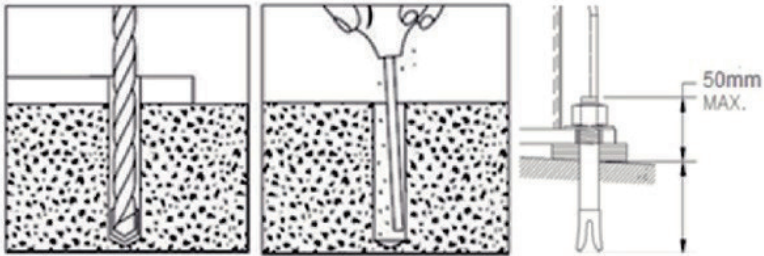

- Fix the auxiliary post by reference to the mounting method of main post, and check that the difference between the diagonal distances of the two post bottom plates is not more than 3mm.
- Prepare the ladder cart for the two posts respectively, fasten both sides of the gantry with slings, lift the gantry, and then install the connecting bolts.

**Note: The irrelevant personnel shall be kept away from the lift during the installation of gantry.**

- Tighten the expansion bolts (reference torque: 203N.m), and meanwhile check that the post is vertical with a spirit level. Place the gasket at the bottom of the post to level the post if necessary. Check that the upper surface of the gantry is level with a spirit level.

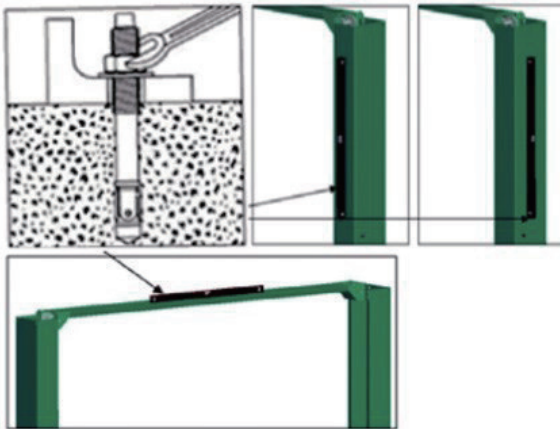

Note: If the tightening torque of expansion bolt cannot reach 203N.m, the strength of concrete shall be rechecked. 4.8 Install the roof collision-prevention limit rod and connect the limit switch.

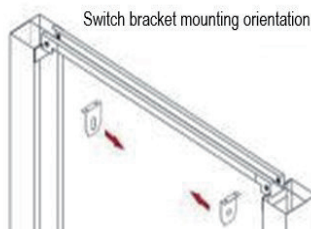

### - Installation of balance wire rope

Make sure that the left and right sliding tables are at the first safety position, and then install the balance wire rope as per the track shown in the figure. Do not tighten the nut temporarily as the tension of two wire ropes will be adjusted for synchronization later on. Note: The screw rod for the left or right wire rope must be tightened. Make sure that the left & right sliding tables are locked at the same height during adjustment.

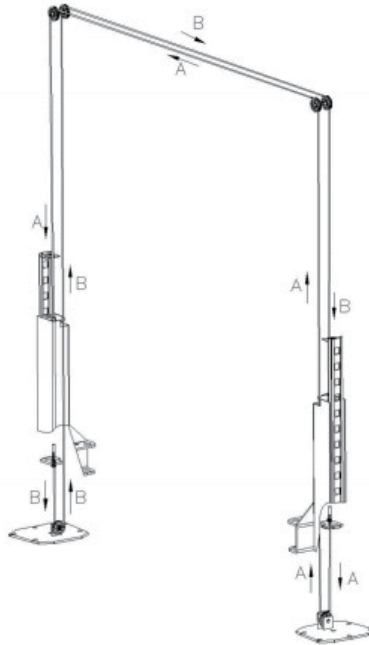

### - Installation of bracket arm

Install four bracket arms into the sliding table through the pin, with three-section straight arms at the front end and two-section straight arms at the back end. (Note: The three-section bracket arms shall be installed at the front end and each arm is required to be installed with a circlip.)

当小齿跟大齿距离调整后，把大齿固定螺丝拧紧  
After making sure the lock match perfectly, tightening the screws.

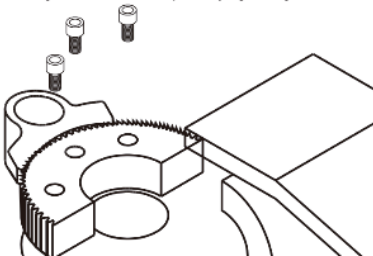

### - Connection of hydraulic system

- Unscrew the hydraulic tank cap and add 10L 46# anti-wear hydraulic oil. (46# anti-wear hydraulic oil is preferred; 32# anti-wear hydraulic oil is preferred at a temperature below -10° C)
- Connect the hydraulic joint and connect the oil pipe to the oil outlet joint of the main and auxiliary cylinders.

- Connection of electric unlocking wires

The connection of the electric unlocking wires is as shown in the figure below: connect them to the terminals 2 and 7, 9 and 10 of control cabinet respectively.

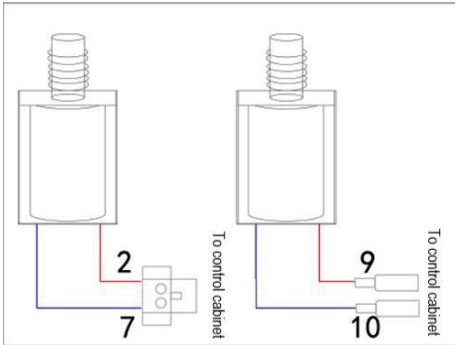

- Installation of electric unlocking safety lock:

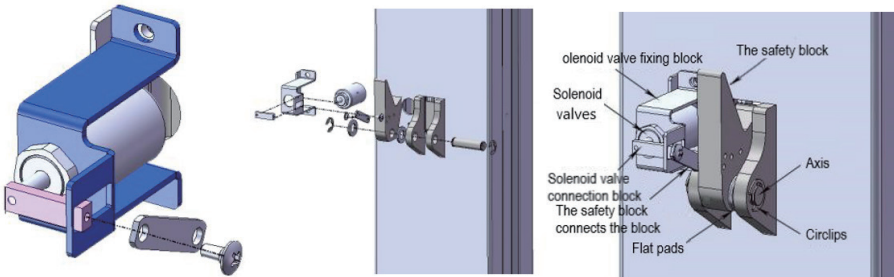

Note:

Add general lithium base grease (GB7324-87) to the gap between the safety lock and the shaft. Ensure that the safety lock is safe and reliable during normal use. If the safety lock cannot be reset, stop the machine immediately and resume operation after troubleshooting.

- Adjustment for no-load test

- Clean the site and check that there is no oil stain on the ground and the lift is unloaded.
- Power on the lift, press UP button to lift the sliding table and then stop at any position. Then, press the oil return handle to lower the left and right sliding tables to the same safety position.
- Tighten the balance wire rope nut to keep the tension of the two balance wire ropes basically the same.
- Press the UP button to lift the sliding table until it is out of the safety position, and then pull the safety handle with the left hand and press the oil return handle with the right hand to lower the sliding table to the lowest position.
- Press the UP button to lift the sliding table continuously (if the limit switch is triggered when the sliding table is at any position, the motor will stop). After the limit position is reached, the relief valve will open, the oil will return to the hydraulic system, and the sliding table will stop rising. Observe the synchronization of the left and right sliding table bracket arms during this process, and continue to adjust the tightness of the balance wire rope nut if significant difference exists.

f. Install the door collision-prevention rubber pad.

- Adjustment for load test

- Fully put the four bracket arms aside to ensure that the track is barrier-free.



- b. Drive to the middle position of the lift, and keep the length ratio of the front part to the rear part of the vehicle (for those equipped with front engine) around 2:3 when the connecting line of the posts is taken as a reference. When the tonnage of the vehicle exceeds 3.5T, the vehicle shall be moved backward appropriately.
- c. Rotate the bracket arm tray to the support point of the chassis.
- d. Press the UP button to lift the bracket arms and ensure the 4 bracket arm locks are completely engaged.
- e. Continue to inch it up until a rubber tray has contact with the support point of the chassis, and then rotate other rubber trays counterclockwise to bring them into contact with the support point.
- f. Press the UP button to lift the vehicle slowly until all tires are off the ground. Gently push the rear of the vehicle to check that the vehicle is fixed firmly and the bracket arm locks are completely engaged.
- g. Press the UP button to continue lifting the vehicle and observe if the vehicle is stable during this process. Stop lifting the vehicle when the sliding table rises to the third or fourth safety position, and press the oil return handle, after which the oil will return to the hydraulic station and the sliding table will be locked. Observe if the vehicle is stable. (adjust the balance wire rope nut if there is an obvious height difference between the left side and right side of the vehicle).
- h. Continue to lift the vehicle until it rises to the highest safety position, and then press the oil return handle, after which the oil will return to the hydraulic station and the sliding table will be locked. Observe if the lift is stable without vibration.
- i. Inch the sliding table up until it is out of the safety position, and then pull the safety handle with the left hand and press the oil return handle with the right hand. after which the vehicle will descend. j. Release the safety handle when the sliding table is at any position in the middle, after which the safety lock will rebound automatically, the sliding table will be locked and stop descending.
- k. Inch the sliding table up until it is out of the safety position, pull the safety handle with the left hand and press the oil return handle with the right hand, and then release the safety handle when the sliding table is at any position in the middle, after which the safety lock will rebound automatically, the sliding table will be locked and stop descending. Repeat these operations for more than three times to verify the safety and reliability of the mechanical safety lock.
- l. While lifting the vehicle, check for abnormal sound and friction or interference between the wire rope and other components.



## Chapter V Maintenance Instructions

- Daily maintenance
  - a. Inspect all hydraulic joints, oil pipes, and cylinders for leakage.
  - b. Inspect all electric wires for damage.
  - c. Inspect all moving parts for excessive wear.
  - d. Remove the oil stains on the rubber tray and inspect the rubber tray for excessive wear.
- Maintenance after every 2 months
  - a. Replace the grease in the post slideway.
  - b. Replace the grease on the bracket arm pin.
  - c. Inspect and tighten the nut of expansion bolt.
- Maintenance after every 6 months
  - a. Replace the grease on the chain and wire rope.
  - b. Adjust the balance wire rope and safety rope.
  - c. Inspect the wire rope for burrs.
- Maintenance after every 2 years
  - a. Replace the hydraulic oil.



## Chapter VI Common Faults

S/N	Common Faults	Solution
1	Button fails to work	Replace the button
2	Contactors fails to operate after energization	Replace the contactor
3	The contactor fails to be energized and operate	Inspect the button and limit switch
4	Oil leakage occurs at the connection of hydraulic system	Replace the joint or oil pipe
5	Oil leakage occurs in the cylinder	Replace the sealing ring, or replace the cylinder in the worse case
6	The bracket arm teeth do not engage well	Adjust the position of the bracket arm teeth
7	Safety rope gets loose	Adjust the latch to tighten the safety rope
8	Severe burrs appear on the balance wire rope	Replace the wire rope
	Left and right sliding tables fails to fall to the same safety position	Adjust the balance wire rope nut to synchronize the sliding tables
9	Left and right sliding tables fails to fall to the same safety position	Adjust the balance wire rope nut to synchronize the sliding tables
10	Automatic oil return volume drops	Replace the oil return valve or lowering flow regulating valve
	Abnormal sound is heard in the three-phase motor, or the motor is powerless	Phase loss occurs in the motor, thus inspect the incoming power wire 380VAC with a multimeter
11	No oil is pumped out when the three-phase motor is working	The motor rotates reversely. Replace two adjacent power phase wires (commonly known as live wires)
12	Abnormal sound is heard in the three-phase motor, or the motor is powerless	Phase loss occurs in the motor, thus inspect the incoming power wire 380VAC with a multimeter
13	The lowering speed is too low when the lift is loaded	Inspect if the oil return valve and lowering flow regulating valve are blocked by foreign matters
14	The lift shakes during operation	Apply grease to the post slideway; inspect if the output pressure of the hydraulic station is stable enough; inspect the cylinder piston rod for climbing. (Replace it if any)

## Chapter VII Hydraulic System Diagram and Oil Pipe Routing Diagram

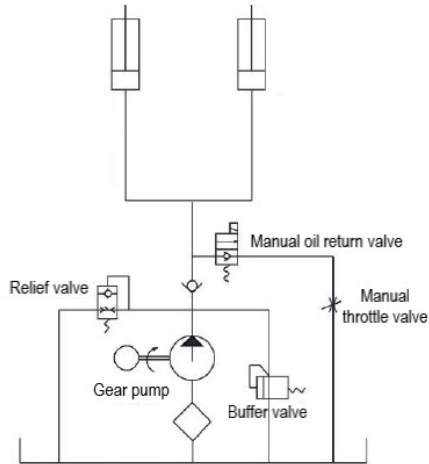

Manual oil return valve: controlling the oil circuit for lowering  
 Manual throttle valve: adjusting the speed of lowering  
 Relief valve: controlling the maximum pressure  
 Gear pump: supplying oil pressure  
 Buffer valve: reducing the motor load when the motor starts

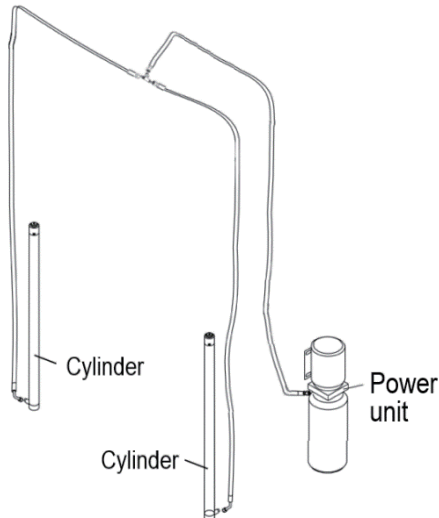



## Chapter VIII Electrical Schematic Diagram

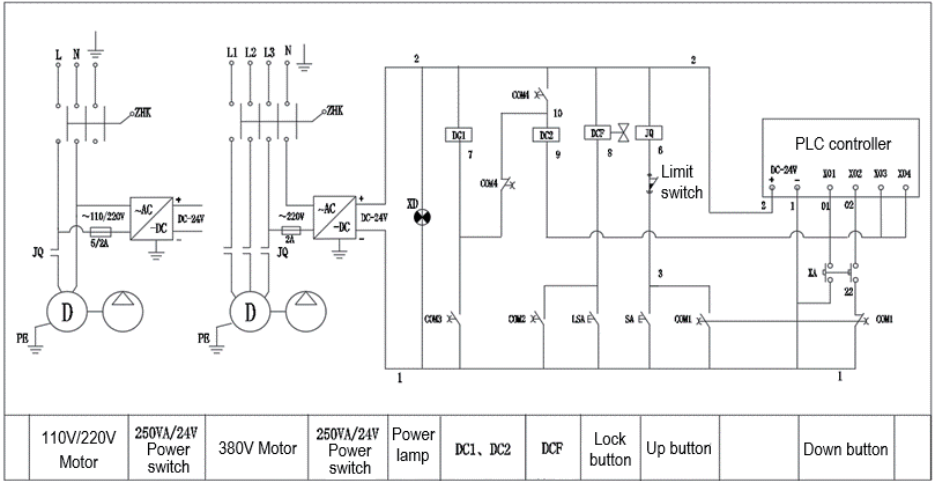

Voltage	Power	Start current	Operating current	Wire size	Air switch	Applicable to
380V	3kw	21A-35A	7A	At least 2.5 mm	C63	Scissor lift
220V	3kw	60A	21A-22A	At least 4mm	C63	Scissor lift
380V	2.2kw	18A-30A	6A	At least 2.5 mm	C63	Two posts, the gantry, four posts
220V	2.2kw	60A	20A	At least 4mm	C63	Two posts, the gantry, four posts

Note: Power supply: to U, V and W; please use the power wires with minimum size of 2.5 mm

Motor: to X, Y and Z.

Travel switch: to J and E. Please connect the C63 air switch with leakage protector

The power access cable is installed	Motor access line mounting method	Motor wire wiring method (this wire has been left outside the wire control box): Red is 3 lines of fire, yellow is the ground line	3, 6 contact limit stroke switch, 2, 8 motor drop valve, 2, 7 and 9, 10 connected to the column on the electromagnet

## Chapter IX Exploded Views

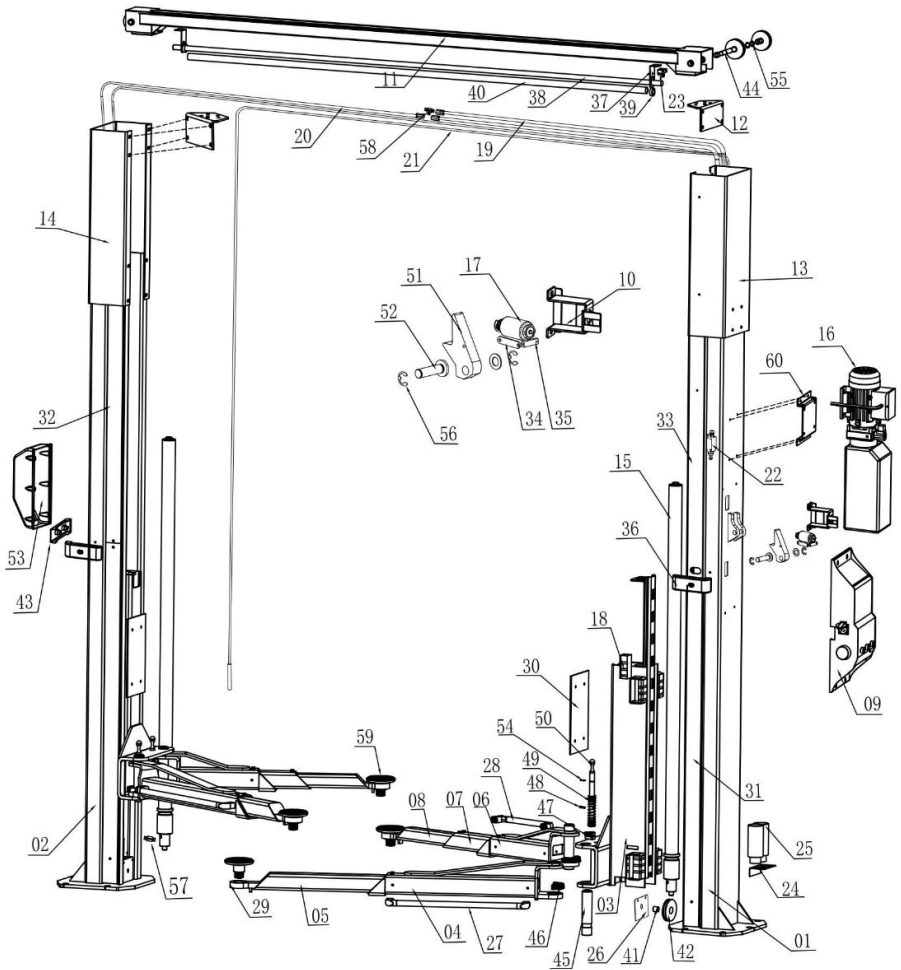

No.	Part No.	Name	No.	Part No.	Name
1	PAE5153-01	Main column	30	PDAE5141-14	Vehicle protection rubber mat
2	PAE5104-02	Secondary columns	31	PAE5153-07	Tubing cover bottom
3	PAE5104-03	slipway	32	PAE5153-08	Tubing cover top (pair)
4	PAE5104-04	Long rocker arm A	33	PAE5153-09	Tubing cover top (main)
5	PAE5104-05	Long rocker B	34	PAE5153-10	Fuse connection block
6	PAE5104-06	Short swingarm A	35	PAE5153-11	Solenoid valve connection block
7	PAE5104-07	Short rocker B	36	PAE5153-12	Large rack trunking block A
8	PAE5104-08	Short swingarm C	37	PDAE5140-12	Top limit switch fixing block
9	PAE5153-02	Electronic control box 220V	38	PDAE5140-13	Limit tube
	PAE5153-03	Electronic control box 380V	39	PDAE5140-14	Limit lever fixing sleeve
10	PAE5153-04	Solenoid valve fixing block	40	PDAE5140-15	Foam sleeve
11	PAE5104-09	crossbeam	41	PDAE5040-37	M20X20 wear ring
12	PAE5104-10	Column connection block	42	PAE5104-16	Wire rope rollers
13	PAE5104-11	The main column is heightened	43	PAE5153-10	Large rack trunking block B
14	PAE5104-12	The column is sub-heightened	44	PDAE5140-16	Beam pulley shafts
15	PDAE5141-07	Cylinder	45	PDAE5040-42	The lower bumper under the rocker arm holds the shaft
16	PDAE5141-08	380V power unit	46	PDAE5040-44	Big gears
	PDAE5141-09	220V power unit	47	PDAE5040-45	Pinion
17	PAE5153-05	Electromagnets	48	PDAE5141-20	5mm open pin
18	PDAE5141-10	Slider A	49	PDAE5040-46	Retractable teeth on the rocker arm
19	PAE5153-06	Short tubing L3080	50	PDAE5040-47	Fuse tie rod shaft on the rocker arm
20	PDAE5141-12	Long tubing L5480	51	PAE5153-13	Fuses
21	PDAE5141-13	Wire rope assembly L10150	52	PAE5153-14	Electric fuse tooth shaft
22	PDAE5040-24	Limit switch	53	PDAE5040-30	Fuse cover A
23	PDAE5140-07	Micro switch	54	PDAE5040-51	M22 circlip
24	PAE5104-13	Heighten the base of the column	55	PDAE5141-21	M20 circlip
25	PDAE5040-27	Heighten the column	56	PDAE5040-53	M17 circlip
26	PDAE5140-08	Large frame base plate wire wheel cover	57	PDAE5040-54	Double-column cylinder long connector
27	PAE5104-14	Long swing arm holding hands	58	PAE5510-85	Tee connector
28	PAE5104-15	Short swing arm handle	59	PAE5104-19	Rectangular pallet assembly
29	PDAE5040-33	Rocker arm adjustment screws	60	PAE5153-15	Power unit mounting rack

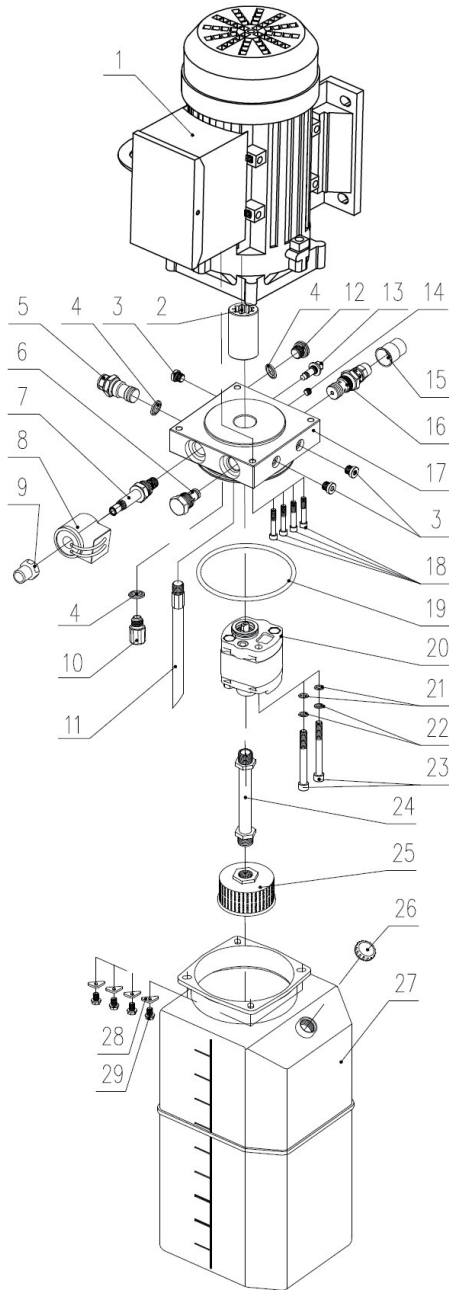

No.	Part No.	Name
1	PDAE5141-24	Aluminum shell motor 220V
	PDAE5141-25	Aluminum shell motor 380V
2	PDAE5040-58	Spline connection sleeve
3	PDAE5040-59	Hexagonal plug
4	PDAE5040-60	Combination washers
5	PDAE5040-61	Trap fittings
6	PDAE5040-62	Check valve
7	PDAE5153-30	Lowering spool
8	PDAE5153-31	Drop valve solenoid
9	PDAE5153-32	Lock nut
10	PDAE5040-66	Buffer valve
11	PDAE5040-67	Return line
12	PDAE5040-68	Hexagonal plug
13	PDAE5040-69	Throttling adjustment screws
14	PDAE5040-70	Φ8 ball blockage
15	PDAE5040-71	Relief valve cover
16	PDAE5040-72	Relief valve
17	PDAE5040-73	Aluminum valve block
18	PDAE5040-74	Hexagonal bolts
19	PDAE5040-75	O-ring
20	PDAE5040-76	Gear pumps
21	PDAE5040-77	Flat gasket
22	PDAE5040-78	Spring pads
23	PDAE5040-79	Hexagonal bolts
24	PDAE5040-80	Nylon suction tube
25	PDAE5040-81	filter
26	PDAE5040-82	Ventilation caps
27	PDAE5040-83	Hanging square plastic oil drum
28	PDAE5040-84	Tank triangle gasket
29	PDAE5040-85	Hexagonal flange bolts

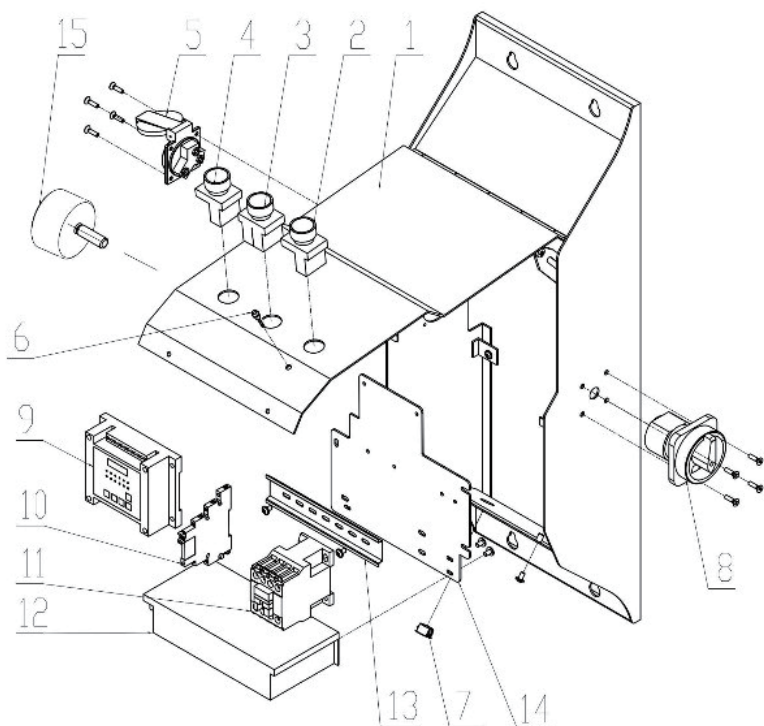

No.	Part No.	Name
1	PAE5153-16	Electronic control box
2	PAE5153-17	Button (Lock)
3	PAE5153-18	Button (drop)
4	PAE5153-19	Button (rising)
5	PAE5153-20	Industrial covered sockets
6	PAE5153-21	LED (red)
7	PAE5153-22	Plug
8	PAE5153-23	Universal transfer switch
9	PAE5153-24	4 programmable time relay
10	PAE5153-25	Chip relay
11	PAE5153-26	AC contactor
12	PAE5153-27	Switching power supply
13	PAE5153-28	Rail
14	PAE5153-29	Electronic control board
15	PAE5104-20	Electrostatic releaser

适用型号 / Model: AE5153EV/AE5153EV-3

版本号 / Version No: V-AE-AE5153EV-2211

世达汽车科技（上海）有限公司

SATA Automotive Technology (Shanghai) Co., Ltd

客户服务：上海市嘉定区南翔镇静唐路 988 号 5-12 幢

Customer service: Building 5-12, No. 988, Jingtang Road, Nanxiang Town, Jiading District, Shanghai

邮编 / Post: 201802

电话 / Tel.: (86 21) 6061 1919

传真 / Fax: (86 21) 6061 1918