

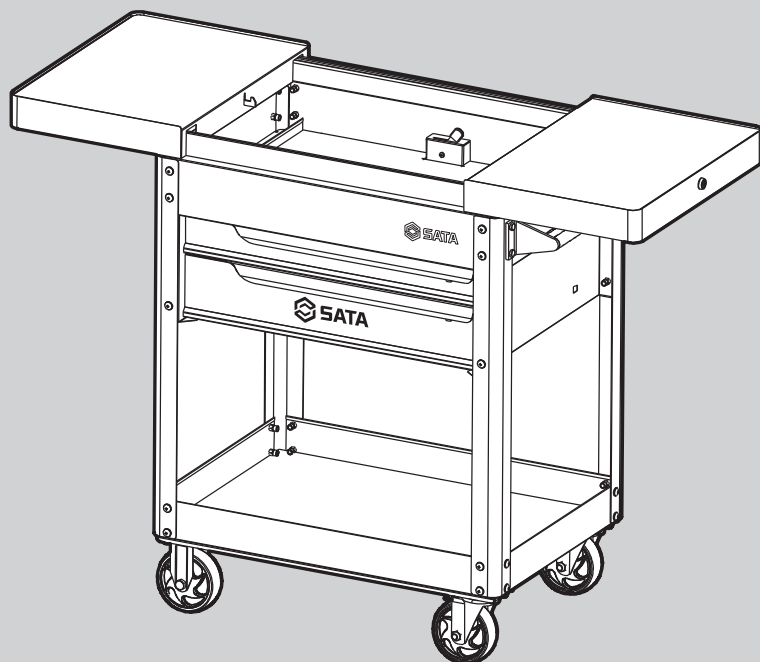

两抽屉滑盖式工具车 2-Drawer Tool Cart With Sliding Cover

95112



使用说明书 \ User's Manual



在使用本产品前，请先仔细阅读此说明书。
请妥善保存此说明书，以备日后查询使用。
Please read these instructions carefully before use.
Please keep these instructions for future reference.



首先非常感谢您选用我们的产品!

在使用前请仔细阅读了解本说明书, 充分了解之后再使用本产品。遇到使用困难或故障时请与经销商或制造商联系, 以免丢失小零件而彻底丧失功能。

安装需要的工具

1. PH2 螺丝刀 

2. 13mm 扳手 

零部件名称

序号	名称	数量
1	工具车主体	1
2	工具车立柱	4
3	立柱螺栓〔套〕	32
4	把手	1
5	把手固定螺栓	4 </td
6	下托盘	1
7	脚轮定轮	2
8	脚轮动轮	2
9	轮脚螺栓〔套〕	16

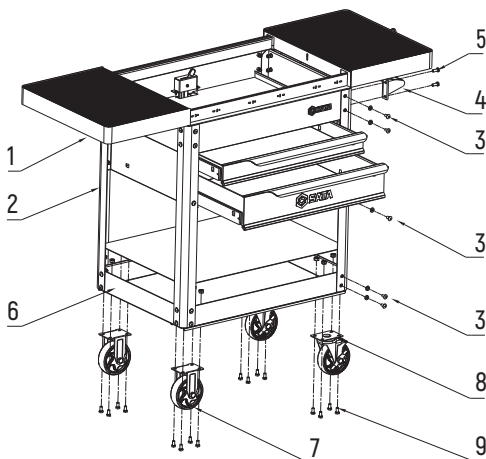

安装步骤

1. 打开工具车包装, 取出工具车主体及零部件。将工具车主体侧放在干净的垫子上, 以防止损坏工具车表面。将 4 个工具车立柱依次用立柱螺栓安装在工具车主体上 (把手处不安装立柱螺栓) (图 1)
2. 将托盘倒置, 将下托盘依次用立柱螺栓安装在 4 个立柱上 (图 2)
3. 将工具车脚轮用脚轮螺栓依次安装在工具车托盘底部上 (动轮需与把手安装位置同侧) (图 3)
4. 将工具车翻回正常位置, 并将把手用立柱螺栓安装在工具车上 (把手需安装在脚轮动轮同侧) (图 4)



图 1



图 2

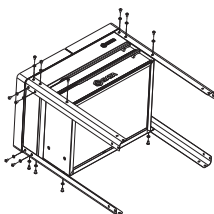

图 3

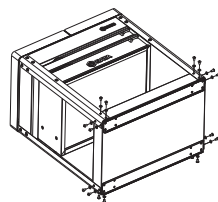

图 4

First of all, thank you very much for choosing our product!

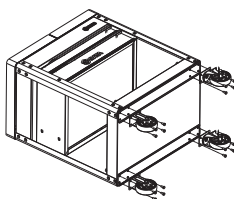
Please carefully read and understand this manual before use, and only use this product after fully understanding it. Please contact the dealer when encountering difficulties or malfunctions in use. Or contact the manufacturer to avoid losing small parts and completely losing functionality.

Tools required for installation

1. PH2 screwdriver

2. 13mm wrench

Part List

No.	Name	Qty.
1	Tool cart body	1
2	Tool car pillar	4
3	Pillar bolt (set)	32
4	Handle	1
5	Handle fixing bolt	4
6	Lower tray	1
7	Castor fixed wheel	2
8	Castor driven wheel	2
9	Wheel foot bolt (set)	16

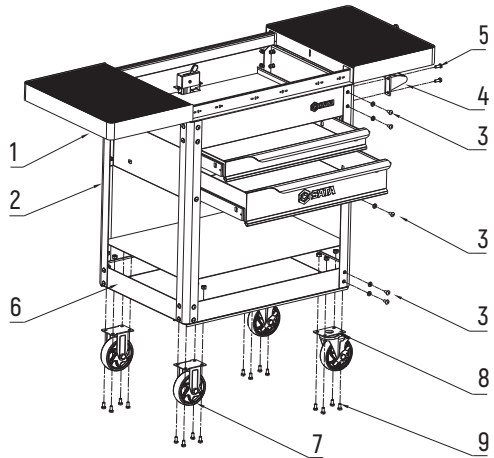

Installation steps

1. Open the packaging of the tool cart and remove the main body and components of the tool cart. Place the tool owner's body on a clean cushion to prevent damage to the surface of the tool car. Install the four pillars of the tool cart one by one onto the main body of the tool cart using pillar bolts (do not install pillar bolts at the handle) (Fig. 1)
2. Invert the tray and install the lower tray onto the four pillars using column bolts in sequence (Fig. 2)
3. Install the tool cart casters onto the bottom of the tool cart tray using casters bolts in sequence (the moving wheels must be installed on the same side as the handle) (Fig. 3)
4. Flip the tool cart back to its normal position and install the handle onto the tool cart using column bolts (the handle needs to be installed on the same side of the casters) (Fig. 4)

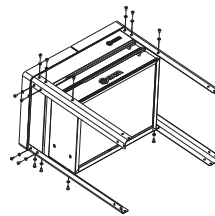

Fig. 1

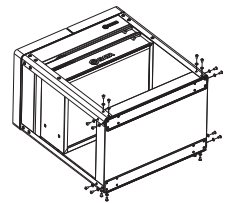

Fig. 2

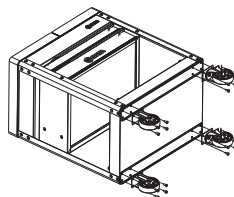

Fig. 3



Fig. 4

适用型号 / Model :

95112

版本号 / Version No. :

V-SE-95112-240207

世达工具（上海）有限公司
SATA TOOL (SHANGHAI) LIMITED

客户服务：上海市碧波路 177 号 3 楼

Customer service: 3rd Floor, No. 177 Bibo Road, Shanghai

邮编 / Post: 201203

电话 / Tel.: (86 21) 6061 1919

传真 / Fax : (86 21) 6061 1918