



加强型自吸式气动液压拉钉枪 Ø4.8
Self-suction Air-Hydro Blind Riveter Ø4.8

02715



使用说明书 \ User's Manual



气源连接图

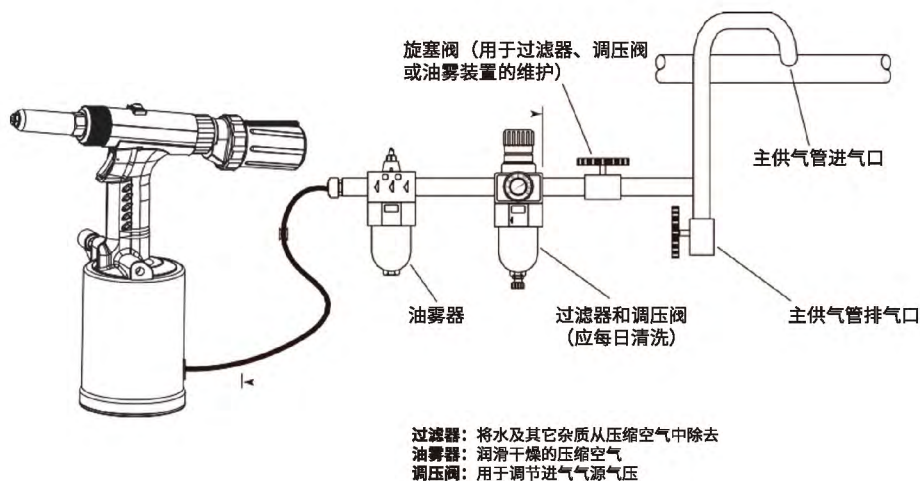

产品介绍

非常感谢您使用我们的产品，请在使用产品之前，请必须先仔细阅读产品说明书。

未得到我司的许可或未授权的情况下，仿制产品或相关内容的复制是属于违法侵权行为。由于本产品不断进行升级改良，因此我们保留产品升级换代的权利。

操作说明书

本手册说明中如果看到“**▲ 警告**”或“**▲ 注意**”字符时，是涉及到安全的重要事项，请仔细阅读严格遵守。

安全使用说明

▲ 警告

- 请严格按说明书来操作，并重点阅读警告和注意事项，并保证安全操作。
- 本手册中并未详细讲解维修操作。无经验的人员请勿随意拆解。经过培训的专业维修人员除外。
- 如果操作不当，或其它重要部位破损。是发生事故的原因。
- 使用本产品前，请确保您已经仔细阅读过本说明书。本说明书介绍会使您更好的操作本产品。

 **警告**

- 收集筒内钉杆满于 1/3 时，请及时倒出，以免断钉杆阻塞内孔造成工具无法正常使用。

 **警告**

- 如果将产品借与他人使用时，请连同说明书一起附带。
——错误使用是受伤和事故的原因之一
- 使用本产品，作业人员应对使用工具有一定的了解与认识。
——如果作业员对本产品不了解，请仔细阅读说明书
- 本产品属于气动液压工具，使用时必须要借助空气压缩机提供动力。
——选择铆接工具时请注意选择性能匹配的型号
- 请勿在以下环境下使用本产品，因为有可能对人体或工具造成伤害。
 - ① 汽油、轻油等有燃料的地方
 - ② 有烟火，急剧温度上升的地方
 - ③ 挥发性溶剂高的地方
 - ④ 腐蚀性气体发生的地方
 - ⑤ 暴风雨，降雪、强风、雷等的天气恶劣时
 - ⑥ 水中和海中
 - ⑦ 使用时有障碍物的地方
- 高空作业时，请确认周边环境及安全措施，因为它也是发生事故的原因之一。
- 产品跌落，请小心处理。
——如果不小心将产品跌落，请仔细检查各部位，是否损坏。
- 请在空气压力 0.5 ~ 0.7 MPa 的范围内使用。
——气压偏低或偏高，均会影响工具性能及寿命。
——长时间的使用液压油会出现损耗，导致气动工具无力 / 行程不足或其它故障。请定期检查添加，以保证性能正常。
- 更换附件时请截断气源。
- 请检查气动连接管牢固性。
——气动连接软管未接好，会造成事故和伤害。
- 拆卸空气软管时，一定要将供气系统关闭。
- 气动连接软管乱摆，会造成事故和伤害。

 **警告**

- 注意空气软管周围不能有障碍物
——如果被软管缠绕或太凌乱易造成人身事故和伤害。

- 产品转移或移动时请将软管开关关闭
——突然碰到开关，可能有受伤或事故发生的危险。

注意

- 定期检查产品保养，如有破损或故障请及时排除请务必安装油水分离器及油雾发生器
——有效延长产品使用寿命，大幅减少故障。
- 工具工作时不要直对着排气口
——排气口可能会有油污喷出，进入眼睛和嘴巴的可能。造成人身安全。
——孩子和幼儿靠近工作场所是非常危险的一种行为。

重要

- 空气压缩机功率，软管长度和直径范围会影响工具的正常使用寿命
——空气压缩机容量小或软管直径细。直接影响工具拉力。
- 软管内径建议在 8.0mm 或更大。
——如果软管内径过小，造成供气量过低，将不能满足产品需要，性能大大降低。
- 注意保护工具，勿用外力敲击，防止机械损坏。

产品说明

本产品是目前国内先进的气动铆接工具，它以压缩空气为动力，使气缸产生推力，通过在油缸中的液压油增压，达到拉断铆钉的目的，具有拉力大、行程长、速度快、重量轻、操作方便、噪音低、采用无振动设计，有效保护操作者手腕免受劳损等优点。

本产品的液压部分采用全套进口优质密封件，多处关键部位均应用航空级铝材，需往复运动零件全部做镜面加工并热处理。整枪使用寿命及工作稳定性极高，尤其适用于进行高频率 \ 高强度连续拉铆作业的用户，是真正的工业级工具。

本系列抽芯铆钉气动工具，广泛适用于汽车、集装箱行业、机械制造业、船舶工业、航空航天等行业，是当今理想的铆接工具；并适用于铝、铜、铁、不锈钢等各种材质 \ 规格铆钉的铆接。

技术参数：

铆接范围：	3.2-4.8MM
工作气压：	0.5MPa ~ 0.7MPa
工具重量：	1.28kg
工作行程：	19mm
工作拉力：	9500N

产品维修与保养

1) 更换三爪 (6#)、顶芯弹簧 (8#)、顶芯 (7#) 步骤:

- 1) 徒手将螺盖 (1#) 逆时针方向旋下, 连同外套筒 (4#) 一起从工具上拔出并卸下。
- 2) 用左手拉住快换滑套 (10#), 右手旋下夹紧套筒 (5#)
- 3) 取出爪片 (6#) 顶芯 (7#) 顶芯弹簧 (8#) 注: 及时清理里面的碎屑
- 4) 按卸下来的步骤, 反向装回

小提示: 安装螺盖 (1#) 与外套筒 (4#) 可以将工具通上气源, 按住扳机, 这样相关装配使 2 个零件只会更加方便快捷。

2) 更换液压油:

小提示: 当铆枪使用一段时间后, 液压油会发生损耗, 会出现行程缩短不能将铆钉一次性拉断, 出现此状况时请及时更换液压油。

- 1) 用内六角扳手将放油螺钉 (19#) 旋下 (检查组件垫圈 18#, 是否损坏, 若损坏请及时更换)。
- 2) 接通气源, 将 (41# 气源开关) 的开关向上滑到位打开气源开关, 让注油孔对着废油收集筒, 然后按下扳机将废油清空。

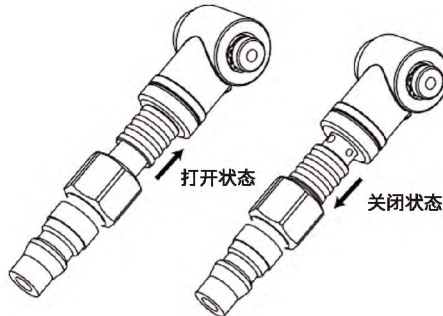

3) 用加油针筒添加液压油步骤:

- 3.1) 接通气源, 将 (41# 气源开关) 的开关向上滑到位打开气源开关, 将吸满液压油的注油针筒, 旋于加油螺丝孔内, 并旋紧。
- 3.2) 推动加油针筒的推杆, 感觉有明显阻力时, 慢慢松开针筒推杆, 注满后旋出针筒并锁紧放油螺钉组件。

3) 添加润滑脂

小提示: 铆枪连续使用 12-14 万次后, 【气缸 (57#) 内壁 / 活塞上面 O 型圈 (53#) / 主气管组件 (51#)】添涂润滑脂, 可以有效的防止密封件磨损, 提高铆钉复位速度。

- 1) 将铆枪正放, 用内六角扳手将 4 个盘头螺钉 (38#) 卸下, 将气缸 57# 拔出,
- 2) 将气缸活塞盘清洁干净后, 用毛刷将润滑脂均匀涂抹在【O 型圈 (53#), 气缸 (57#) 内壁, 主气管组件 (51#) 外径】完成后将气缸 (57#) 套上对角旋紧盘头螺钉 (38#)
- 3) 接上气源反复扣动扳机完成操作。

常见故障及排除方法

故障现象	原因	排除方法
拉铆打滑	爪处磨损或操作	更换爪片
	夹紧套筒爪片有碎屑	清理碎屑后滴 2 滴润滑油
	顶芯弹簧疲劳失效	更换顶芯弹簧
	枪头与钉杆不匹配	使用匹配枪头
拉铆卡钉	夹紧套筒、爪片内有碎屑	清理碎屑后滴 2 滴润滑油
	夹紧套筒、枪头与外套筒没有旋紧	旋紧各个部件
	铆钉钉杆堵住枪头内孔	更换正确枪头
	顶芯内孔有弯顶芯和碎屑	取出并清理后再使用
铆钉拉不断	爪片磨损或损伤	更换爪片
	气压不足	调整气压至规定值
	铆枪液压油缺少	添加液压油
铆枪无动作	没有气压或气压不足	调整气压至规定值
	超出铆枪的拉铆力	选用相应铆枪型号
钉杆插不进	枪头内孔不匹配	更换正确枪头
	爪片没有调圆	夹紧套筒逆时针旋 1 格

附件

序号	编号	品名	数量
1	SCP02715-68	枪头 [VG/3.2] 标配	1
2	SCP02715-69	枪头 [VG/4.0] 标配	1
3	SCP02715-06	三爪	1 付
4	SCP02715-71	吊环	1
5	SCP02715-72	扳手	1
6	SCP02715-73	塑料针筒组件	1

爆炸图

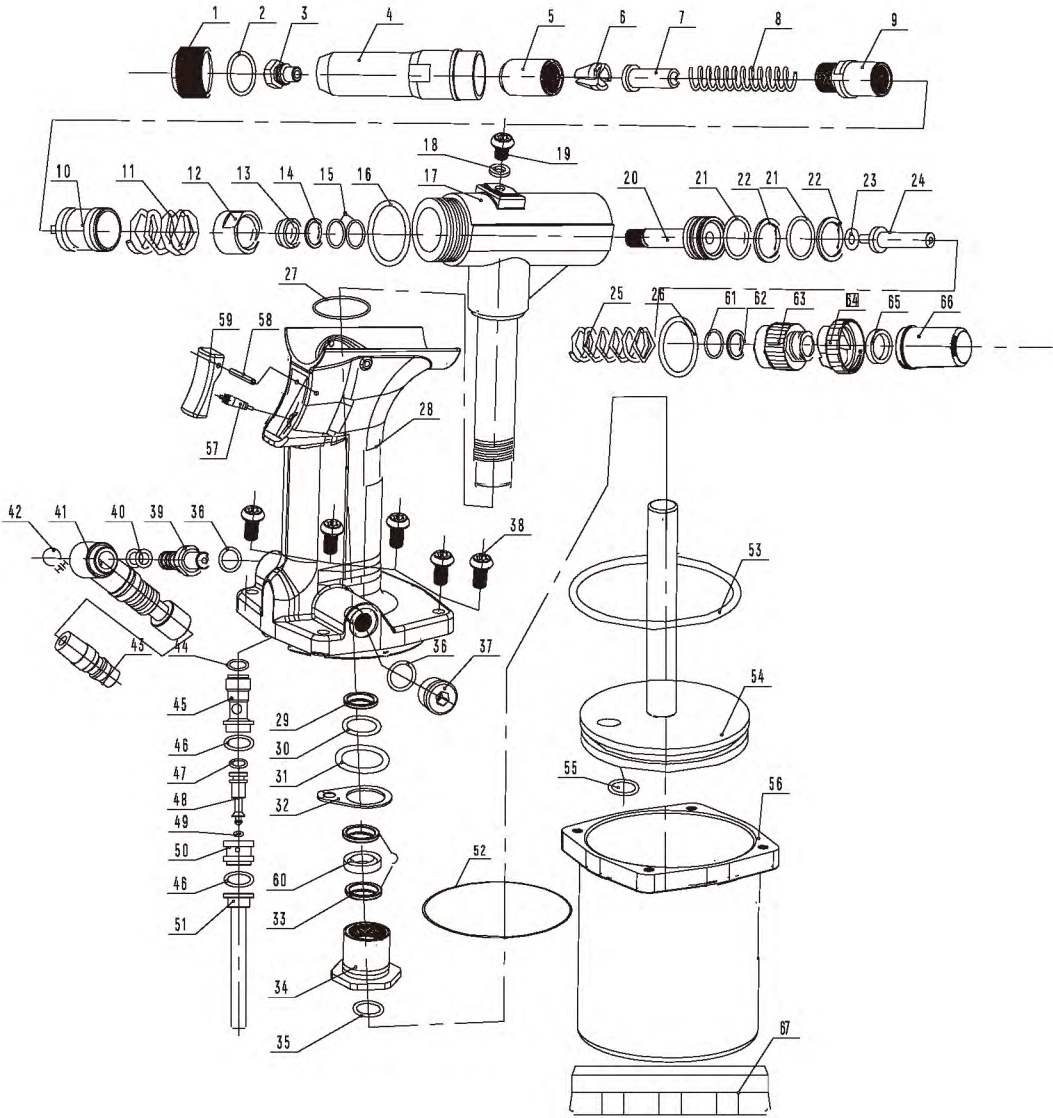

零件清单

序号	配件编号	名称	数量
1	SCP02715-01	螺盖	1
2	SCP02715-02	"O"型圈	1
3	SCP02715-03	枪头 [VG/4.8] 标记	1
4	SCP02715-04	外套筒组件	1
5	SCP02715-05	夹紧套筒	1
6	SCP02715-06	三爪	1
7	SCP02715-07	顶芯	1
8	SCP02715-08	顶芯弹簧	1
9	SCP02715-09	弹簧套筒	1
10	SCP02715-10	快换滑套	1
11	SCP02715-11	快换弹簧	1
12	SCP02715-12	调整锁母	1
13	SCP02715-13	防尘圈 (DZ)	1
14	SCP02715-14	头部支撑圈	1
15	SCP02715-15	"O"型圈	2
16	SCP02715-16	"O"型圈	1
17	SCP02715-17	头架体组件	1
18	SCP02715-18	自定心组合垫圈	1
19	SCP02715-19	放油螺钉	1
20	SCP02715-20	活塞轴结合件	1
21	SCP02715-21	"O"型圈	2
22	SCP02715-22	活塞轴支撑圈	2
23	SCP02715-23	"O"型圈	1
24	SCP02715-24	吸钉管组件	1
25	SCP02715-25	复位弹簧	1
26	SCP02715-26	"O"型圈	1
27	SCP02715-27	"O"型圈	1
28	SCP02715-28	手柄组件 (世达绿)	1
29	SCP02715-29	油缸锁母支撑圈	1
30	SCP02715-30	"O"型圈	1
31	SCP02715-31	"O"型圈	1
32	SCP02715-32	锁母垫圈	1
33	SCP02715-33	活塞杆支撑圈	2
34	SCP02715-34	油缸锁母	1
35	SCP02716-35	上隔圈	1
36	SCP02716-36	"O"型圈 (DZ)	2

序号	配件编号	名称	数量
37	SCP02715-37	上盖闷头螺钉 (黑色)	1
38	SCP02715-38	盘头内六角螺钉	4
39	SCP02715-39	接头螺钉组件	1
40	SCP02715-40	"O"型圈	2
41	SCP02715-41	气源开关总成 (黑色)	1
42	SCP02715-42	轴用弹性挡圈 A 型	1
43	SCP02715-43	气动快速接头	1
44	SCP02715-44	"O"型圈	1
45	SCP02715-45	上隔圈	1
46	SCP02715-46	"O"型圈 (DZ)	2
47	SCP02715-47	"O"型圈	1
48	SCP02715-48	控制杆	1
49	SCP02715-49	密封圈	1
50	SCP02715-50	下隔圈	1
51	SCP02715-51	主气管组件	1
52	SCP02715-52	"O"型圈	1
53	SCP02715-53	"O"型圈	1
54	SCP02715-54	活塞总成	1
55	SCP02715-55	"O"型圈	1
56	SCP02715-56	气缸	1
57	SCP02715-57	气门阀芯	1
58	SCP02715-58	扳机销	1
59	SCP02715-59	扳机	1
60	SCP02715-60	U型圈	1
61	SCP02715-61	"O"型圈	1
62	SCP02715-62	尾部支撑圈	1
63	SCP02715-63	压簧圈结合件	1
64	SCP02715-64	钉筒连接座	1
65	SCP02715-65	连接座锁母	1
66	SCP02715-66	集钉筒	1
67	SCP02715-67	托盘	1

Air Supply

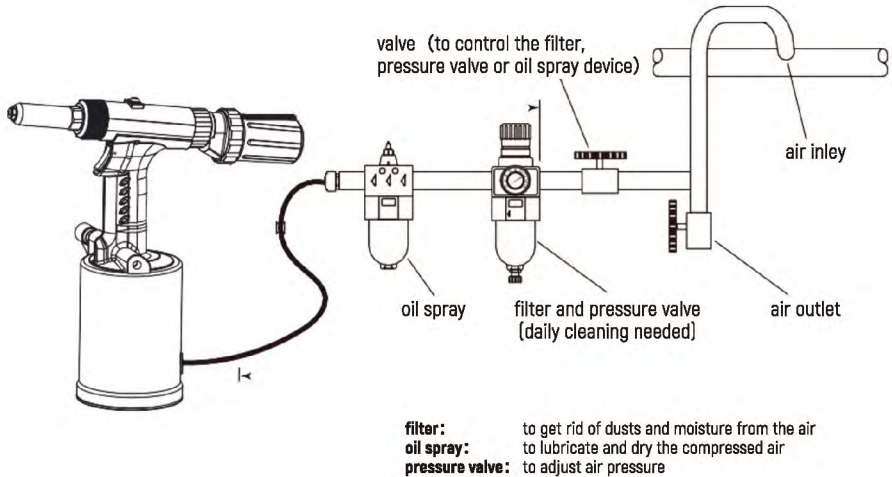

About the Products

We thank you for using our tools, please read this manual carefully before use. Any copying our tools or partial without our approval is the infringement of our property. We reserve the rights to keep upgrade of our tools without notifications.

About the Manual

⚠ It is very important to read the part with warranting. It is related to the safety related instructions.

Safety

⚠ WARNING

- For your safety when use the tools, read this manual carefully and follow the manual in operations.
- This manual does not narrate all the details in repair of the tools. Please do not uninstall the tools unless it carried out by skilled personnel.
- Any misoperations might cause damages of the tools and accidents.
- For the use of the tools, please read this manual carefully.

⚠ WARNING

The rest mandrels in the mandrel colleter over 1/3 of its capacity, please empty it in time, in order to preventing the tools blocked by the rest mandrels.

Notice in Use

WARNING

- Please always have this manual put in the tool kit.
 - Miss operations might cause possible injuries and accident.
- Users of this tool should have good understandings of the tool.
 - Please read this manual carefully when use the tool.
- It is a pneumatic and hydraulic powered tool.
 - The tool needs use compressed air supply
- To prevent from any possible injuries and damages to the tool, please do not use the tool in the following described environments:
 - 1) inflammable substances or gas
 - 2) flames and temperature increasing
 - 3) volatile solvent
 - 4) corrosive gas
 - 5) thundering, humidity or rain
 - 6) water
 - 7) barriers in application spot
- To be sure in safe surroundings when work in high place where might.
- Cause possible accident.
 - Check the tool when it dropped.
 - To check carefully if any damaged of the tool after dropping.
- To use the air supply between the pressure range 0.5MPa–0.7MPa.
 - Air pressure too high or too low will impact on tool performance and life.
 - The hydraulic oil will have loss if the tool not used for a long time, and it will cause the tool getting less power and stroke. Check and refill the hydraulic oil before use.
- To change parts of the tool, please disconnect the air supply.
- To check the air hose.
 - Air hose connection not proper will cause accident and injuries.
- To install the air hose, be sure the air supply is stopped.
- Mislacing of the hose might cause accident and injuries.

WARNING

- To lay the hose properly in no barrier surroundings.
 - Intertwining of the hose might cause accident and injuries.
- To switch off the air supply when the tool is moving away.
 - A sudden touch on the tool switch might cause injuries or accident.

 **NOTICE**

- To use filter for air supply and check and maintenance of the tool periodically.
——It helps the tool's life and reduce the breakdowns.
- Tool vent when in use
——There is a vent of the tool in use, and the oil from the vent might hurt people's eyes and mouth, be careful when tool in use.
——It is dangerous when children in or near the place where the tool is in use.
- Do not hold the tool with the nose or mandrel release towards people or animals in order to prevent from any accident and injuries.

 **IMPORTANT**

- The power of air compressor, hose length and diameter will impact on the tool performance.
——Too small power of the air compressor, too small diameter of the hose will reduce the traction power of the tool.
- To use the hose diameter no less than 8.0mm.
——If the hose diameter is too small, it cause insufficient air supply and impact on the performance of the tool.
- To take care of the tool, not to strike the tool and preventing any mechaical damages.

Advantages of the Tool

It is an advanced riveting tool in domestic market. It is powered by compressed air, and it generates power in the air cylinder and increases the hydraulic power in the oil cylinder in order to set the rivets. The tool has big power and long stroke, quick speed in operation, light in weight and easy to operate. The tool is designed low noise and non-vibration, effectively protects operators.

All the high quality seals in hydraulic system of the tool are imported overseas. Aviation grade aluminium alloy is used in many positions of the tool, and the dynamic parts parts surfaces are mirror finished and heat treated. The tool is durable and stable, suitable for high frequent, high strength and long time use, and it is an industrial level tool.

This series of riveting tools are widely used in automobile, container making, mechenary, vessel building and aviation and aero space industries. It is an ideal series of riveting tools nowadays and appicable in applications of aluminium, copper, steel, stainless steel varies materials riveting.

Specifications

capacities:	3.2-4.8mm
air supply:	0.5MPa ~ 0.7MPa
weight:	1.28kg
stroke:	19mm
traction power:	9500N

Repair and Maintenance

(1) change 3-jaw set (#6), pusher spring (#8), pusher (#7):

- 1) unscrew retaining ring (#1) together with front sleeve (#4)
- 2) hold the sleeve (#10) and unscrew the clamping sleeve (#5)
- 3) take out jaws (#6), pusher (#7) and pusher spring (#8)
- 4) install back the parts back to the tool in reverse order

tips: when install retaining ring (#1) and front sleeve (#4), for quicker and easy install, air supply can be connected and press the button and hold.

(2) change hydraulic oil

tips: After a period of use, the hydraulic oil will get less, and the stroke becomes less, then it is necessary to change the hydraulic oil.

- 1) remove the screw (#19) by socket head wrench, check and change washer (#18) if damaged;
- 2) connect the air supply, slide the switch (#41) to ON position, align the oil-filling hole to a wastes container, press the button to get rid of the hydraulic oil;

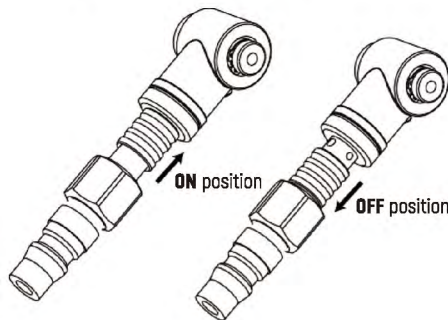

- 3) to fill the oil by injector:
 - 3.1) with air supply and switch (#41) ON position, screw on the injector with hydraulic oil into the oil-filling hole tightly;
 - 3.2) push the injector to fill the oil and stop when full. Unscrew out the injector and screw on back to the hole with the screw

(3) Lubricants

tips: When tool has got about 120 000 ~ 140 000 rivets, inside of air cylinder (#57), O-ring (#53), hose end (#51) should be lubricated. It helps parts life and speed up the operation.

- 1) put the tool upright, unscrew out the 4 screws (#38), take out air cylinder (#57);
- 2) clean the piston plate, add on lubrication grease on O-ring (#53), inside of air cylinder (#57), hose end (#51) with a brush. Install back the air cylinder (#57), screw on the screws (#38) back to the tool.
- 3) with air supply and press the button, repeat several times.

Troubles Shooting

Problems	Causes	Solutions
rivet slipping	jaws worn off	change with new jaw sets
	chips in clamping sleeve	clean and lubricate
	pusher spring fatigue	change with new pusher spring
	wrong nosepiece used for the rivet in use	use the correct nosepiece
rest mandrel blocked	chips in clamping and jaws set	clean and lubricate
	loosen of clamping sleeve, nosepiece and front sleeve	fasten tight of the parts
	rest mandrel blocked in the nosepiece	use the correct nosepiece
	pusher deformed or chips in pusher	change with new pusher or clean the pusher
no breaking of rivet mandrels	jaws worn off or damaged	change with new jaws set
	low air pressure supply	adjust the air supply pressure
	short of hydraulic oil	refill hydraulic oil
tool no performance	no air supply or too low air pressure	adjust the air supply
	riveting beyond tool capacity	to use the correct model
rivet can not be inserted into the nosepiece	not correct nosepiece used	use the correct nosepiece
	3 pieces of the jaws set not aligned well	unscrew the clamping sleeve one thread

Accessories Pack

No.	Part No.	Descriptions	Qty.
1	SCP02715-68	nosepiece (VG/3.2)	1
2	SCP02715-69	nosepiece (VG/4.0)	1
3	SCP02715-06	3-jaw set	1 set
4	SCP02715-71	hook	1
5	SCP02715-72	wrench	1
6	SCP02715-73	injector	1

Exploded View

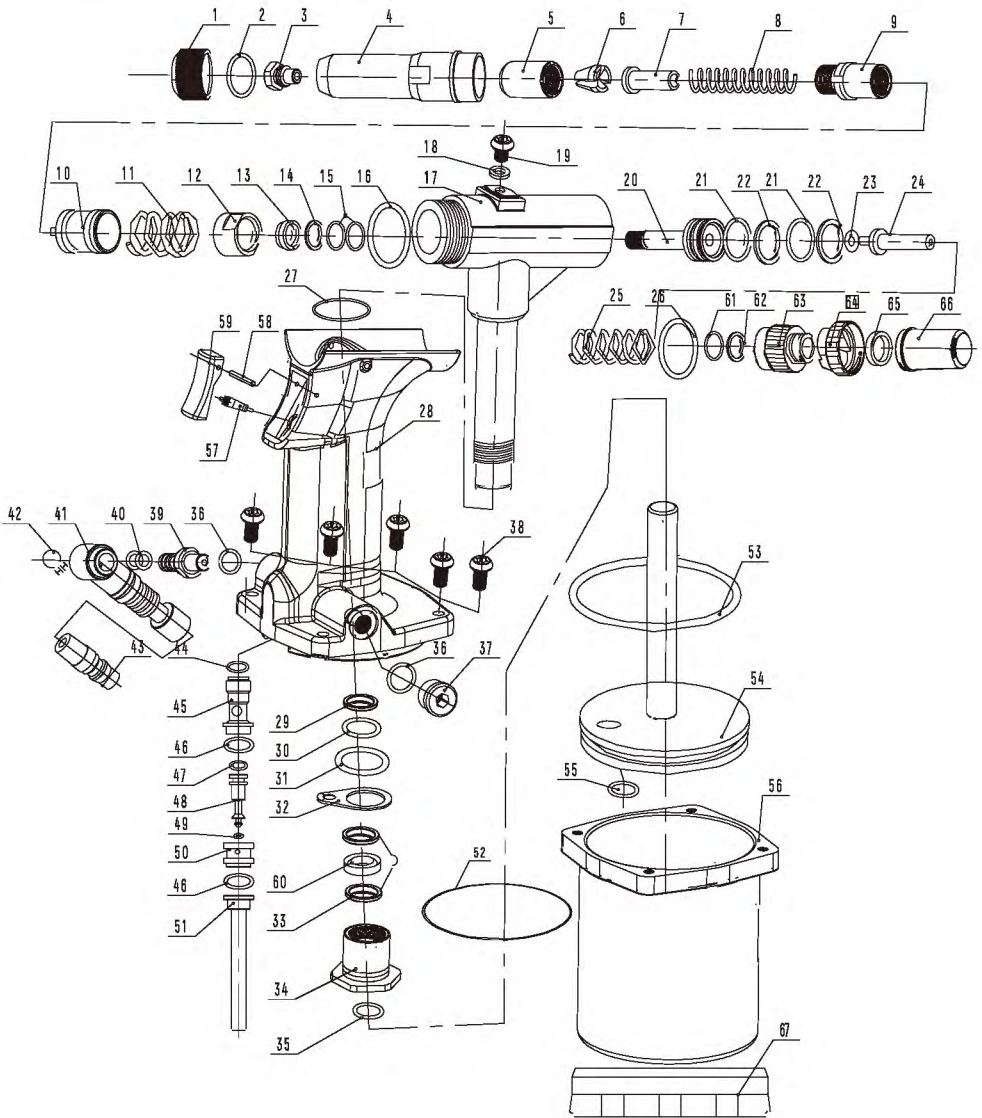

Parts List

Parts ID	Part No	Parts Descriptions	Qty.
1	SCP02715-01	retainingring	1
2	SCP02715-02	O-ring	1
3	SCP02715-03	nosepiece(VG/4.8)	1
4	SCP02715-04	frontsleeve	1
5	SCP02715-05	clampingsleeve	1
6	SCP02715-06	3-jawset	1
7	SCP02715-07	pusher	1
8	SCP02715-08	pusherspring	1
9	SCP02715-09	springsleeve	1
10	SCP02715-10	slider	1
11	SCP02715-11	spring	1
12	SCP02715-12	nut	1
13	SCP02715-13	dustring	1
14	SCP02715-14	supportring	1
15	SCP02715-15	O-ring	2
16	SCP02715-16	O-ring	1
17	SCP02715-17	oilcylinder	1
18	SCP02715-18	washer	1
19	SCP02715-19	screw	1
20	SCP02715-20	pistonpin	1
21	SCP02715-21	O-ring	2
22	SCP02715-22	supportring	2
23	SCP02715-23	O-ring	1
24	SCP02715-24	mandreltube	1
25	SCP02715-25	returnspring	1
26	SCP02715-26	O-ring	1
27	SCP02715-27	O-ring	1
28	SCP02715-28	grip	1
29	SCP02715-29	supportring	1
30	SCP02715-30	O-ring	1
31	SCP02715-31	O-ring	1
32	SCP02715-32	washer	1
33	SCP02715-33	supportring	2
34	SCP02715-34	nut	1
35	SCP02715-35	O-ring	1
36	SCP02715-36	O-ring	2

Parts ID	Part No	Parts Descriptions	Qty.
37	SCP02715-37	blockageend	1
38	SCP02715-38	screw	4
39	SCP02715-39	screwadaptor	1
40	SCP02715-40	O-ring	2
41	SCP02715-41	airadaptorswitch	1
42	SCP02715-42	circlip	1
43	SCP02715-43	airadaptor	1
44	SCP02715-44	O-ring	1
45	SCP02715-45	uppervalve	1
46	SCP02715-46	O-ring	2
47	SCP02715-47	O-ring	1
48	SCP02715-48	valvepin	1
49	SCP02715-49	seal	1
50	SCP02715-50	lowervalve	1
51	SCP02715-51	hose	1
52	SCP02715-52	O-ring	1
53	SCP02715-53	O-ring	1
54	SCP02715-54	piston	1
55	SCP02715-55	O-ring	1
56	SCP02715-56	aircylinder	1
57	SCP02715-57	airvalve	1
58	SCP02715-58	pin	1
59	SCP02715-59	button	1
60	SCP02715-60	U-ring	1
61	SCP02715-61	O-ring	1
62	SCP02715-62	supportring	1
63	SCP02715-63	springhouse	1
64	SCP02715-64	mandrelcollectoradaptor	1
65	SCP02715-65	locknut	1
66	SCP02715-66	mandrelcollector	1
67	SCP02715-67	bottom	1

适用型号 / Model :

02715

版本号 / Version No. :

V-SE-02715-210820

世达工具（上海）有限公司
SATA TOOL (SHANGHAI) LIMITED

客户服务：上海市浦东新区碧波路 177 号 A 座 302 室

Customer service: Room 302, Area A, No. 177, Bibo Road, Pudong New Area, Shanghai

邮编 / Post: 201203

电话 / Tel.: (86 21) 6061 1919

传真 / Fax : (86 21) 6061 1918